

## OVERALL SOLUTIONS FOR ROBOTIC END-EFFECTOR

- ★ EOAT FOR STAMPING
  - EOAT FOR TANDEM PRESS LINE
  - EOAT FOR TRANSFER LINE
  - EOAT FOR HOT FORMING LINE
- ★ PNEUMATIC GRIPPERS
- ★ ELECTRIC GRIPPERS
- ★ ROBOTIC TOOL CHANGERS
- ★ HYDRAULIC CLAMPS

### Jinan Aotto Technologies Co., Ltd.

Addr: Room 801, Building 3, Zone 2, Jianda Hexin Industry Base,  
Jinan Innovation Valley Accelerator , Changqing District,  
Jinan City, Shandong Province, China.

Website: <https://aotto.en.alibaba.com>

Email: [Marketing@aotto.cn](mailto:Marketing@aotto.cn)

Tel: 0531- 87201565

Web: [www.aottotech.com](http://www.aottotech.com)



Learn more  
Ver. 2026-04

## PNEUMATIC GRIPPERS

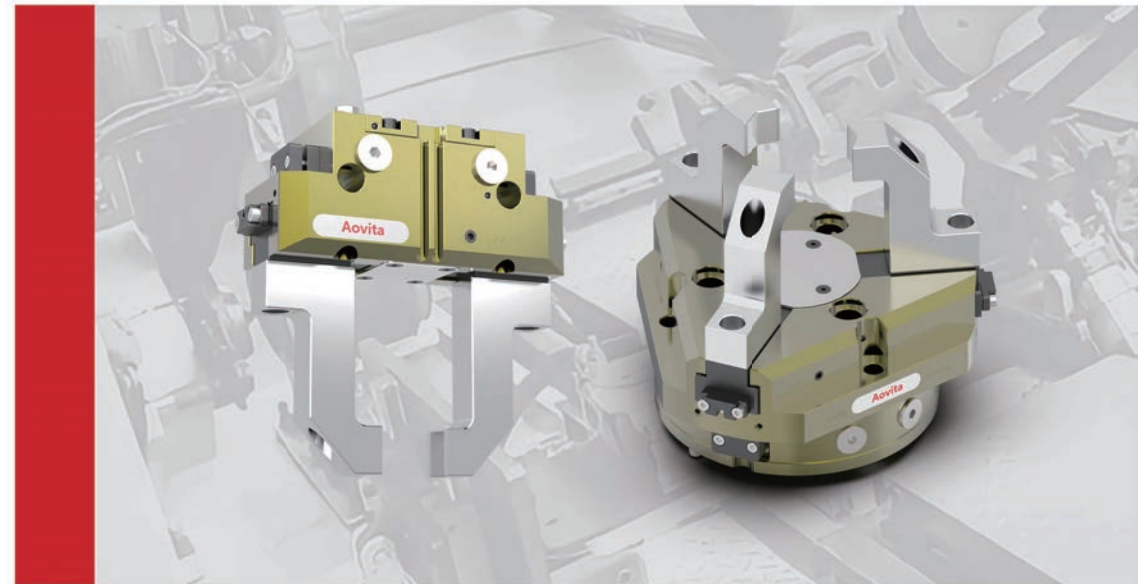

Since **2000**

Jinan Aotto Technologies Co., Ltd.

# Aotto



## Aovita®

Jinan Aotto Tooling Team implements the mission of "promoting industrial upgrading with advanced automation products and services, creating value for customers and society", and strives to create **Aovita®** intelligent grabbing products.

The **Aovita®** team adheres to the core concept of Aotto "dedication to innovation and pursuit of excellence", using the "high reliability" of the product to improve the startup rate of automatic lines, reduce maintenance costs, and use the "high cost-effectiveness" of the product to reduce overall equipment investment, promoting the popularization of automation. We are committed to creating a one-stop supply platform for intelligent grabbing products. We have products with robot tool changer, vacuum products, gripper products, magnetic suction products, needle grabbing products, and could provide overall intelligent gripping solutions.

## CONTENTS

- Product Information ..... P01
- PET Parallel Gripper ..... P03
- PST Centric Gripper ..... P21
- ARU Rotary Unit ..... P39
- ATU Rotary Wrist ..... P49
- ACU Flexible Compensation Unit ..... P61
- AEM Magnetic Chuck ..... P79
- **Aovita** Product List ..... P83

## □ Pneumatic gripper

The **Aovita** pneumatic gripper mounts on industrial robots. It grips and handles workpieces. Combined with the robot, it holds and transfers parts like a human hand.

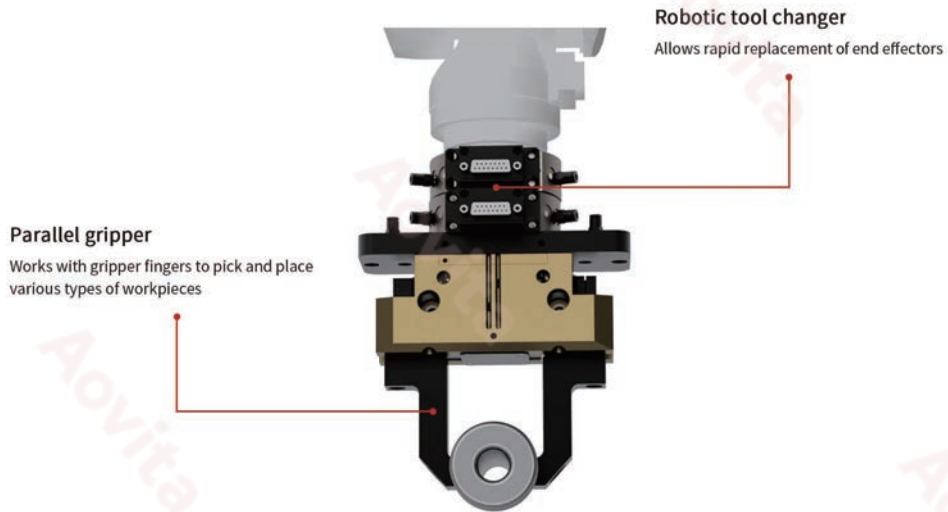

### Parallel gripper

Works with gripper fingers to pick and place various types of workpieces

### Robotic tool changer

Allows rapid replacement of end effectors

## □ Advantages

### ■ Cost Reduction & Cost Efficiency Improvement

- Key components feature customized surface treatment and self-lubricating design in critical areas, providing excellent wear and corrosion resistance, minimal maintenance, and high reliability.
- Supports continuous and stable automation, reducing personnel and maintenance expenses while lowering costs and improving efficiency.

### ■ Quality & Value

- ISO 9001 quality management system with full production process control ensures consistent quality.
- Strict control of raw material sources, combined with customized surface and heat treatment processes as well as in-house manufactured core components, ensures high manufacturing precision and consistent product quality.
- Focused on providing high cost-performance robotic peripherals that reduce overall equipment investment and promote widespread automation adoption.

### ■ Versatility

- Compact design delivers high gripping force with minimal interference.
- Standardized mounting interfaces ensure compatibility with leading grippers.
- High-strength aerospace aluminum body ensures excellent rigidity while minimizing the additional load on the robot.
- All models support multiple mounting and air connection configurations.

### ■ Safety

- Features a fully enclosed T-slot heavy-duty guide rail, elliptical piston drive and wedge transmission mechanism for robust structure and stable gripping.
- Built-in open/close and piston position sensors enable mechanical self-locking on air loss or pressure-holding self-locking, ensuring safe and reliable automated production.

## □ Application

**Aovita** pneumatic grippers are ideal for handling and assembling medium to large parts across industries such as machining, automotive components, casting and forging, new energy, packaging, and education/research.



◀ Parallel grippers for holding shaft-type/flange-type components

◀ Centric gripper for holding ring-shaped/shaft-type components



Machining



Automotive



Packaging



New Energy



Education



# Aovita PET Parallel Gripper

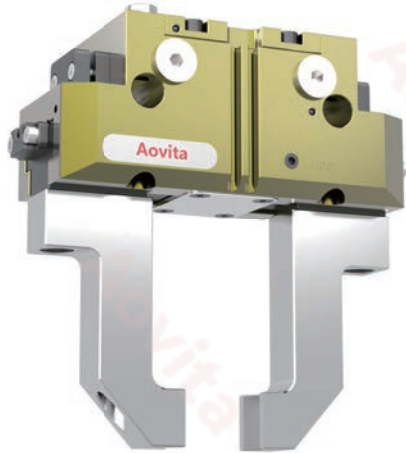

- Reliable
- Stable
- Flexible

## Application

Universal solution for multiple industries. Ideal for mechanical engineering, assembly & material handling, and automotive production – in clean to lightly dusty environments.

## Advantages

- ① Robust T-slot guide rail for precise gripping of diverse workpieces.
- ② Comprehensive sensors for versatile querying possibilities and stroke position monitoring.
- ③ Maximum piston surface area for maximum gripping force.
- ④ The wedge-hook design ensures high force transmission and synchronous gripping.
- ⑤ Mounting interfaces on three sides for universal and flexible gripper assembly.
- ⑥ Air supply via hose-free direct connection or screw connections for universal and flexible gripper assembly.

Sizes  
8

Weight  
0.3-18Kg

Gripping force  
200-11700N

Stroke per jaw  
3-35mm

Workpiece weight  
1-50Kg

# Optional Modules

Tailored to industry-specific requirements

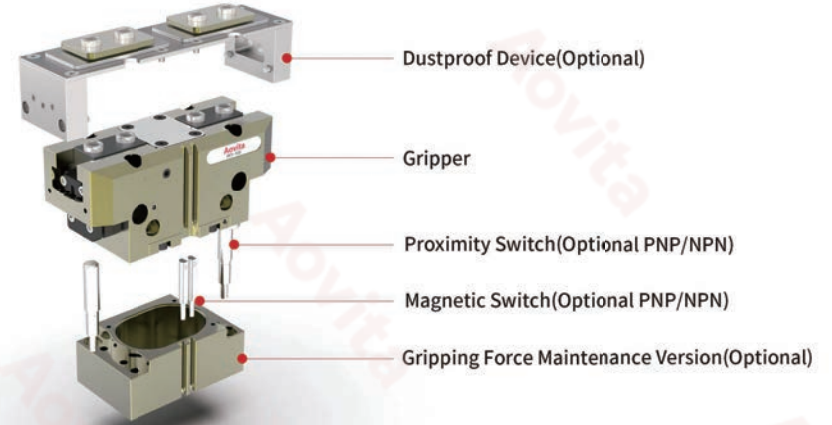

Note: Each gripper requires a minimum of two sensors (one for open position, one for closed position).

Model	Stroke per jaw [mm]	Gripping force (Closing) [N]	Gripping force (Opening) [N]	Workpiece weight [kg]	Gripper weight [kg]
PET-64	6	200	240	1	0.3
	3	400	480	2	0.3
PET-80	8	400	450	2	0.5
	4	800	900	3.5	0.5
PET-100	10	700	750	3	0.8
	5	1300	1400	6	0.8
PET-125	13	1000	1100	5	1.4
	6	2000	2200	10	1.4
PET-160	16	1600	1700	8	2.8
	8	3200	3400	15	2.8
PET-200	25	2700	2800	13	5.5
	14	4500	4800	20	5.5
PET-240	30	4200	4400	20	9
	17	6400	6700	30	9
PET-300	35	6000	6200	30	14
	20	10000	10500	50	14



□ PET-64



■ Gripping force

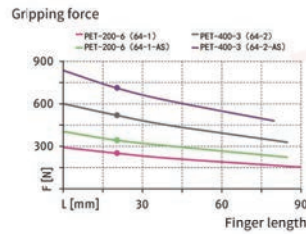

■ Max. load

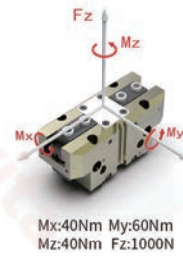

■ Dimensions

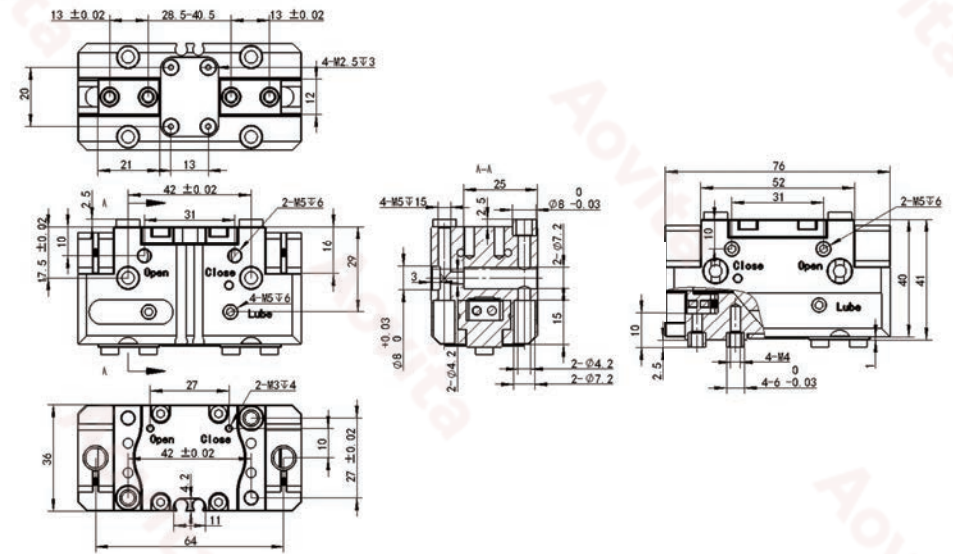

■ Selection

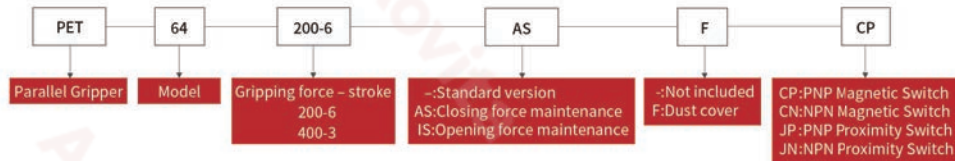

At least two sensors are required for each gripper to detect two positions.

Model	PET-64 200-6	PET-64 200-6-AS	PET-64 200-6-IS	PET-64 400-3	PET-64 400-3-AS	PET-64 400-3-IS
Gripping force(Closing)	200N	280N	/	400N	560N	/
Gripping force(Opening)	240N	/	280N	480N	/	560N
Min. spring force	/	80N	80N	/	80N	80N
Bore size	φ28mm	φ28mm	φ28mm	φ28mm	φ28mm	φ28mm
Workpiece weight	1kg	1kg	1kg	2kg	2kg	2kg
Repeat accuracy	0.02mm	0.02mm	0.02mm	0.02mm	0.02mm	0.02mm
Stroke per jaw	6mm	6mm	6mm	3mm	3mm	3mm
Max. finger length	90mm	90mm	90mm	80mm	80mm	80mm
Max. mass per finger	0.3kg	0.3kg	0.3kg	0.3kg	0.3kg	0.3kg
Operating air pressure	0.25-0.8MPa	0.4-0.8MPa	0.4-0.8MPa	0.25-0.8MPa	0.4-0.8MPa	0.4-0.8MPa
Rated working pressure	0.6MPa	0.6MPa	0.6MPa	0.6MPa	0.6MPa	0.6MPa
Closing/opening time	0.02s	0.02/0.04s	0.04/0.02s	0.02s	0.02/0.04s	0.04/0.02s
IP class	IP40	IP40	IP40	IP40	IP40	IP40
Air consumption per cycle	10ml	17ml	17ml	10ml	17ml	17ml
Weight	0.3kg	0.4kg	0.4kg	0.3kg	0.4kg	0.4kg
Dimensions	76*36*41mm	76*36*60mm	76*36*60mm	76*36*41mm	76*36*60mm	76*36*60mm
Ambient temperature	0-80°C	0-80°C	0-80°C	0-80°C	0-80°C	0-80°C

① The table shows test values at 0.6 MPa. It may take hundreds of gripping cycles to reach the max. gripping force (indicated in the data sheet).

■ Hose-free direct connection

Refer to this connection method for top air supply.

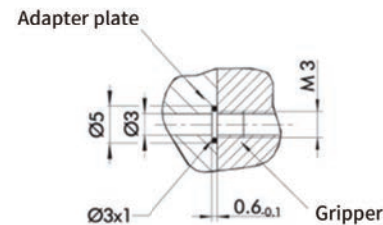

■ Maintenance device(AS/IS)

The gripper maintains minimum gripping force via spring force even if pressure drops. AS: closing force, IS: opening force.

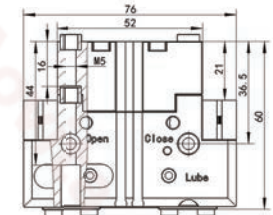

■ Dustproof device(F)

Lube dustproof air port connects to 0.1 MPa positive pressure to achieve IP64.

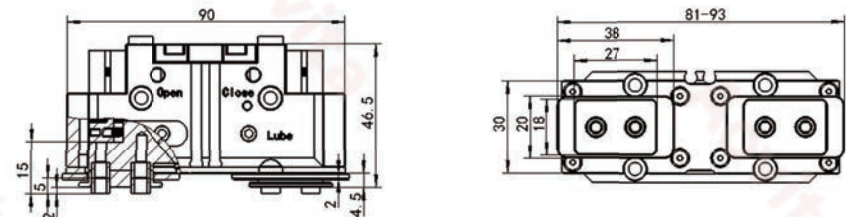

▣ PET-80

■ Gripping force

■ Max. load

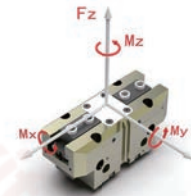
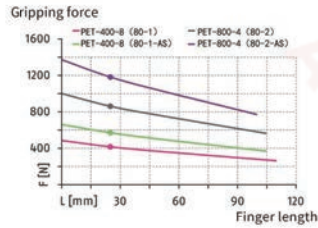
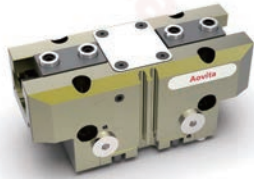

Mx:60Nm My:90Nm  
Mz:50Nm Fz:1500N

■ Selection

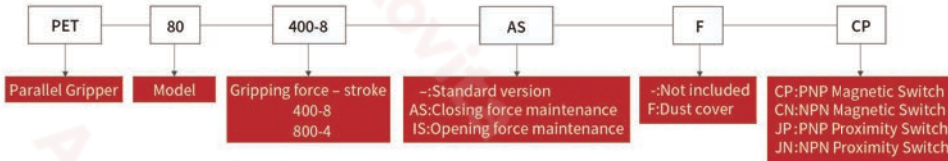

At least two sensors are required for each gripper to detect two positions.

Model	PET-80 400-8	PET-80 400-8-AS	PET-80 400-8-IS	PET-80 800-4	PET-80 800-4-AS	PET-80 800-4-IS
Gripping force(Closing)	400N	520N	/	800N	920N	/
Gripping force(Opening)	450N	/	570N	900N	/	1020N
Min. spring force	/	120N	120N	/	120N	120N
Bore size	φ36mm	φ36mm	φ36mm	φ36mm	φ36mm	φ36mm
Workpiece weight	2kg	2kg	2kg	3.5kg	3.5kg	3.5kg
Repeat accuracy	0.02mm	0.02mm	0.02mm	0.02mm	0.02mm	0.02mm
Stroke per jaw	8mm	8mm	8mm	4mm	4mm	4mm
Max. finger length	110mm	110mm	110mm	100mm	100mm	100mm
Max. mass per finger	0.6kg	0.6kg	0.6kg	0.6kg	0.6kg	0.6kg
Operating air pressure	0.25-0.8MPa	0.4-0.8MPa	0.4-0.8MPa	0.25-0.8MPa	0.4-0.8MPa	0.4-0.8MPa
Rated working pressure	0.6MPa	0.6MPa	0.6MPa	0.6MPa	0.6MPa	0.6MPa
Closing/opening time	0.04s	0.03/0.05s	0.05/0.03s	0.04s	0.03/0.05s	0.05/0.03s
IP class	IP40	IP40	IP40	IP40	IP40	IP40
Air consumption per cycle	23ml	35ml	36ml	23ml	36ml	36ml
Weight	0.5kg	0.6kg	0.6kg	0.5kg	0.6kg	0.6kg
Dimensions	96*42*49mm	96*42*67mm	96*42*67mm	96*42*49mm	96*42*67mm	96*42*67mm
Ambient temperature	0-80°C	0-80°C	0-80°C	0-80°C	0-80°C	0-80°C

① The table shows test values at 0.6 MPa. It may take hundreds of gripping cycles to reach the max. gripping force (indicated in the data sheet).

■ Dimensions

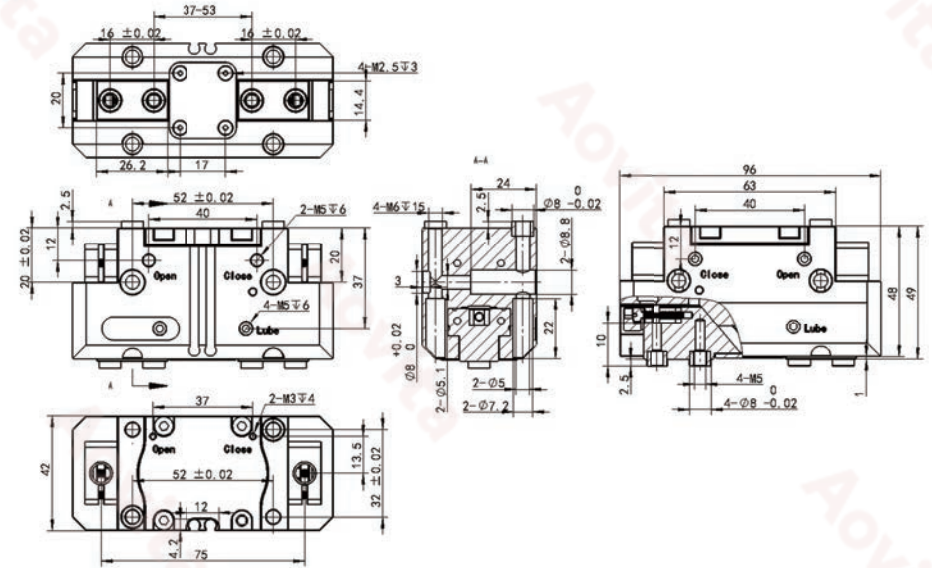

■ Hose-free direct connection

Refer to this connection method for top air supply.

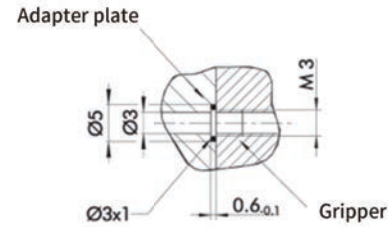

■ Maintenance device(AS/IS)

The gripper maintains minimum gripping force via spring force even if pressure drops. AS: closing force, IS: opening force.

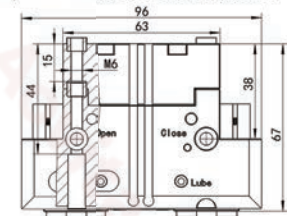

■ Dustproof device(F)

Lube dustproof air port connects to 0.1 MPa positive pressure to achieve IP64.

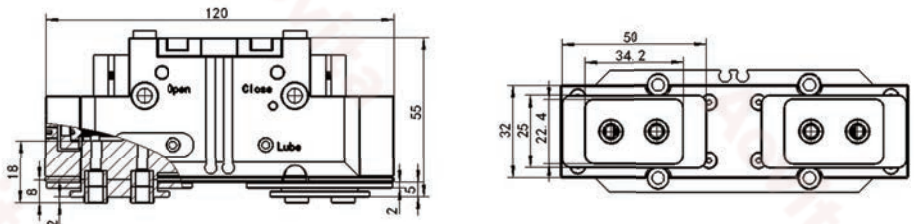



▣ PET-100



■ Gripping force

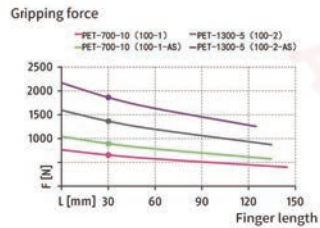

■ Max. load

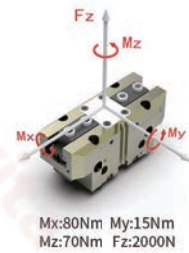

■ Dimensions

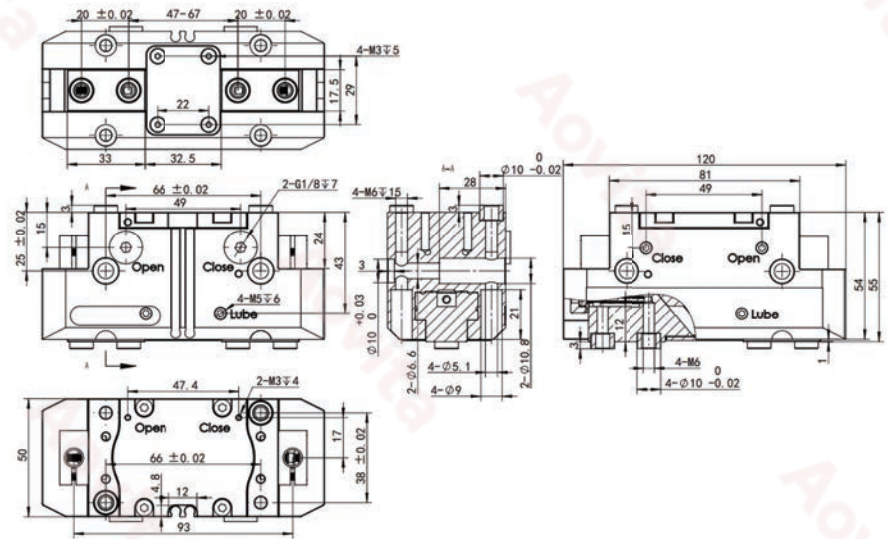

■ Selection

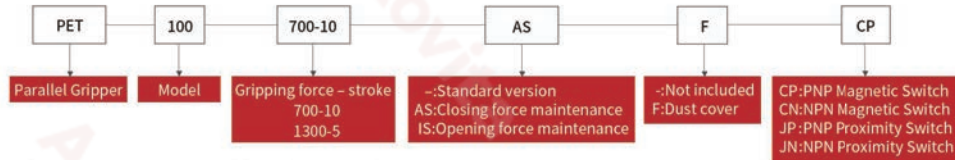

At least two sensors are required for each gripper to detect two positions.

Model	PET-100 700-10	PET-100 700-10-AS	PET-100 700-10-IS	PET-100 1300-5	PET-100 1300-5-AS	PET-100 1300-5-IS
Gripping force(Closing)	700N	900N	/	1300N	1500N	/
Gripping force(Opening)	750N	/	950N	1400N	/	1600N
Min. spring force	/	200N	200N	/	200N	200N
Bore size	φ46mm	φ46mm	φ46mm	φ46mm	φ46mm	φ46mm
Workpiece weight	3kg	3kg	3kg	6kg	6kg	6kg
Repeat accuracy	0.02mm	0.02mm	0.02mm	0.02mm	0.02mm	0.02mm
Stroke per jaw	10mm	10mm	10mm	5mm	5mm	5mm
Max. finger length	125mm	125mm	125mm	110mm	110mm	110mm
Max. mass per finger	1.1kg	1.1kg	1.1kg	1.1kg	1.1kg	1.1kg
Operating air pressure	0.25-0.8MPa	0.4-0.8MPa	0.4-0.8MPa	0.25-0.8MPa	0.4-0.8MPa	0.4-0.8MPa
Rated working pressure	0.6MPa	0.6MPa	0.6MPa	0.6MPa	0.6MPa	0.6MPa
Closing/opening time	0.08s	0.06s/0.12s	0.12s/0.06s	0.08s	0.06s/0.12s	0.12s/0.06s
IP class	IP40	IP40	IP40	IP40	IP40	IP40
Air consumption per cycle	45ml	79ml	79ml	45ml	79ml	79ml
Weight	0.8kg	1.1kg	1.1kg	0.8kg	1.1kg	1.1kg
Dimensions	120*50*55mm	120*50*81mm	120*50*81mm	120*50*55mm	120*50*81mm	120*50*81mm
Ambient temperature	0-80°C	0-80°C	0-80°C	0-80°C	0-80°C	0-80°C

① The table shows test values at 0.6 MPa. It may take hundreds of gripping cycles to reach the max. gripping force (indicated in the data sheet).

■ Hose-free direct connection

Refer to this connection method for top air supply.

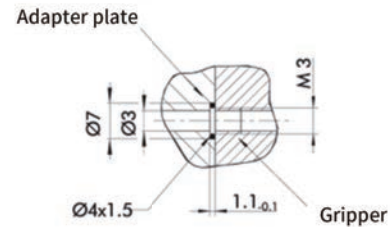

■ Maintenance device(AS/IS)

The gripper maintains minimum gripping force even if pressure drops. AS: closing force, IS: opening force.

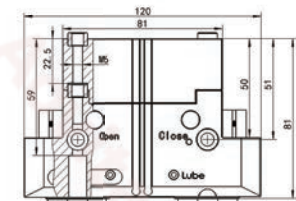

■ Dustproof device(F)

Lube dustproof air port connects to 0.1 MPa positive pressure to achieve IP64.

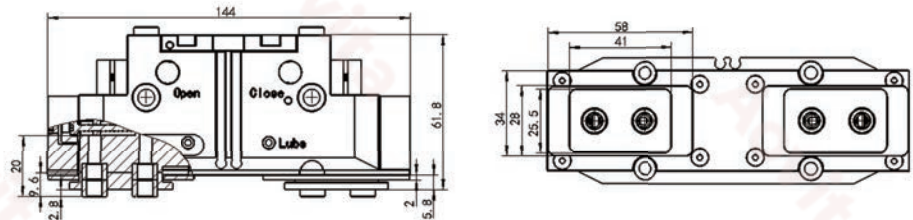



▣ PET-125



■ Gripping force

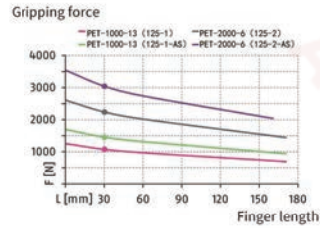

■ Max. load

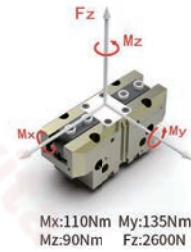

■ Selection

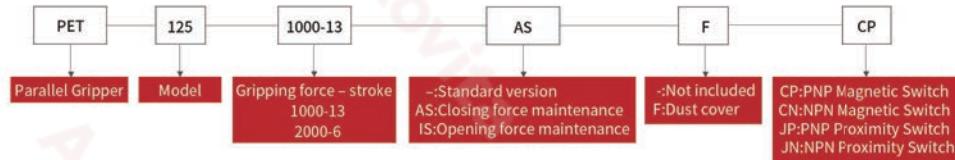

At least two sensors are required for each gripper to detect two positions.

Model	PET-125 1000-13	PET-125 1000-13-AS	PET-125 1000-13-IS	PET-125 2000-6	PET-125 2000-6-AS	PET-125 2000-6-IS
Gripping force(Closing)	1000N	1300N	/	2000N	2300N	/
Gripping force(Opening)	1100N	/	1400N	2200N	/	2500N
Min. spring force	/	300N	300N	/	300N	300N
Bore size	φ57mm	φ57mm	φ57mm	φ57mm	φ57mm	φ57mm
Workpiece weight	5kg	5kg	5kg	5kg	5kg	5kg
Repeat accuracy	0.02mm	0.02mm	0.02mm	0.02mm	0.02mm	0.02mm
Stroke per jaw	13mm	13mm	13mm	13mm	13mm	13mm
Max. finger length	170mm	170mm	170mm	170mm	170mm	170mm
Max. mass per finger	2kg	2kg	2kg	2kg	2kg	2kg
Operating air pressure	0.25-0.8MPa	0.4-0.8MPa	0.4-0.8MPa	0.25-0.8MPa	0.4-0.8MPa	0.4-0.8MPa
Rated working pressure	0.6MPa	0.6MPa	0.6MPa	0.6MPa	0.6MPa	0.6MPa
Closing/opening time	0.1s	0.08s/0.12s	0.12s/0.08s	0.1s	0.08s/0.12s	0.12s/0.08s
IP class	IP40	IP40	IP40	IP40	IP40	IP40
Air consumption per cycle	87ml	119ml	119ml	87ml	119ml	119ml
Weight	1.4kg	1.9kg	1.9kg	1.4kg	1.9kg	1.9kg
Dimensions	151*60*63mm	151*60*93mm	151*60*93mm	151*60*63mm	151*60*93mm	151*60*93mm
Ambient temperature	0-80°C	0-80°C	0-80°C	0-80°C	0-80°C	0-80°C

①The table shows test values at 0.6 MPa. It may take hundreds of gripping cycles to reach the max. gripping force (indicated in the data sheet).

■ Dimensions

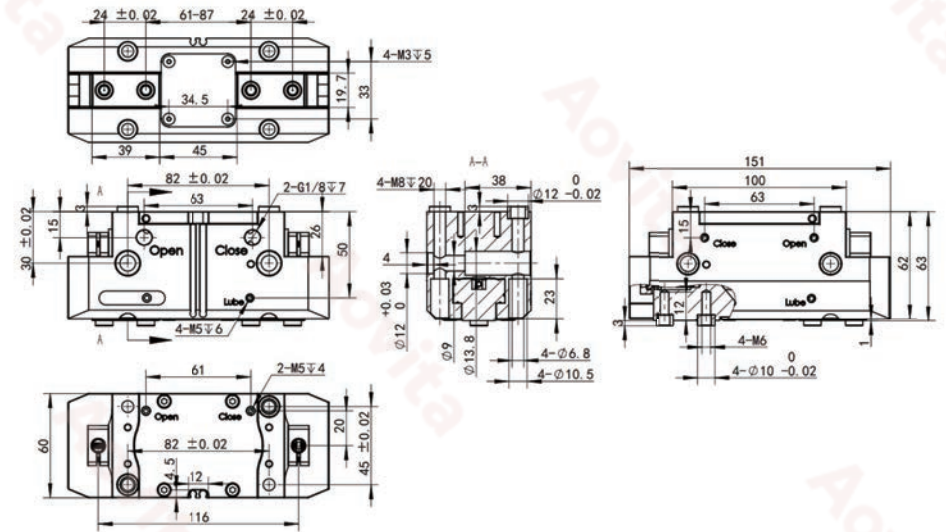

■ Hose-free direct connection

Refer to this connection plate method for top air supply.

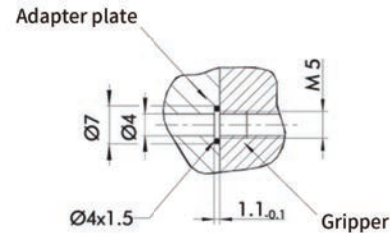

■ Maintenance device(AS/IS)

The gripper maintains minimum gripping force via spring force even if pressure drops. AS: closing force, IS: opening force.

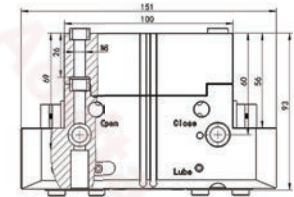

■ Dustproof device(F)

Lube dustproof air port connects to 0.1 MPa positive pressure to achieve IP64.

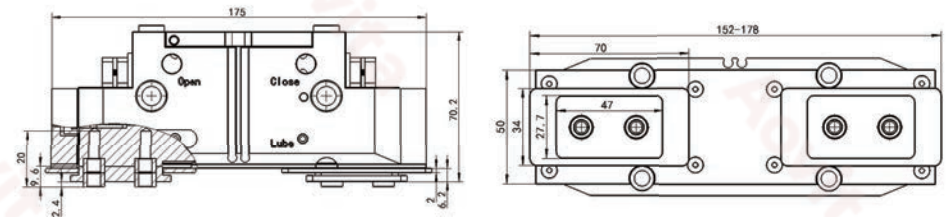

▣ PET-160

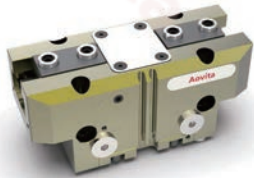

■ Gripping force

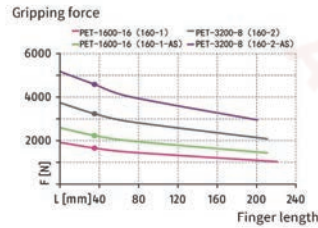

■ Max. load

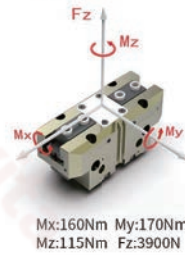

■ Selection

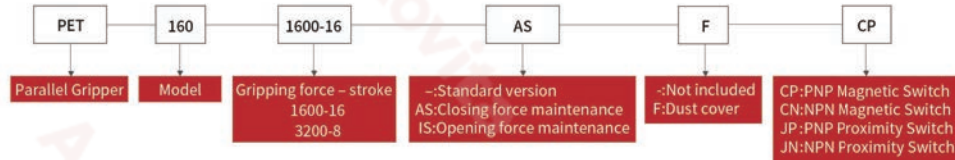

At least two sensors are required for each gripper to detect two positions.

Model	PET-160 1600-16	PET-160 1600-16-AS	PET-160 1600-16-IS	PET-160 3200-8	PET-160 3200-8-AS	PET-160 3200-8-IS
Gripping force(Closing)	1600N	2000N	/	3200N	3600N	/
Gripping force(Opening)	1700N	/	2100N	3400N	/	3800N
Min. spring force	/	400N	400N	/	400N	400N
Bore size	φ72mm	φ72mm	φ72mm	φ72mm	φ72mm	φ72mm
Workpiece weight	8kg	8kg	8kg	15kg	15kg	15kg
Repeat accuracy	0.02mm	0.02mm	0.02mm	0.02mm	0.02mm	0.02mm
Stroke per jaw	16mm	16mm	16mm	8mm	8mm	8mm
Max. finger length	200mm	200mm	200mm	180mm	180mm	180mm
Max. mass per finger	3kg	3kg	3kg	3kg	3kg	3kg
Operating air pressure	0.25-0.8MPa	0.4-0.8MPa	0.4-0.8MPa	0.25-0.8MPa	0.4-0.8MPa	0.4-0.8MPa
Rated working pressure	0.6MPa	0.6MPa	0.6MPa	0.6MPa	0.6MPa	0.6MPa
Closing/opening time	0.15s	0.12s/0.25s	0.25s/0.12s	0.15s	0.12s/0.25s	0.25s/0.12s
IP class	IP40	IP40	IP40	IP40	IP40	IP40
Air consumption per cycle	164ml	210ml	210ml	164ml	210ml	210ml
Weight	2.8kg	3.7kg	3.7kg	2.8kg	3.7kg	3.7kg
Dimensions	192*72*77mm	192*72*117mm	192*72*117mm	192*72*77mm	192*72*117mm	192*72*117mm
Ambient temperature	0-80°C	0-80°C	0-80°C	0-80°C	0-80°C	0-80°C

①The table shows test values at 0.6 MPa. It may take hundreds of gripping cycles to reach the max. gripping force (indicated in the data sheet).

■ Dimensions

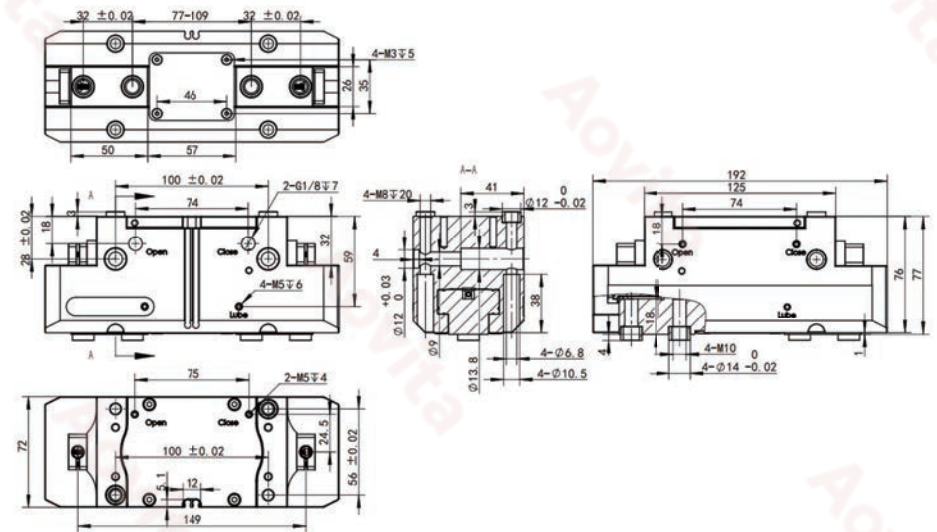

■ Hose-free direct connection

Refer to this connection method for top air supply.

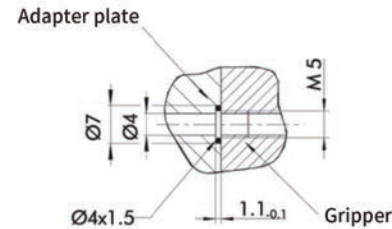

■ Maintenance device(AS/IS)

The gripper maintains minimum gripping force via spring force even if pressure drops. AS: closing force, IS: opening force.

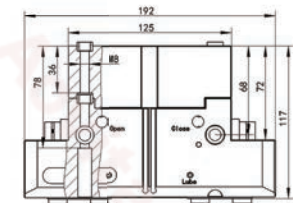

■ Dustproof device(F)

Lube dustproof air port connects to 0.1 MPa positive pressure to achieve IP64.

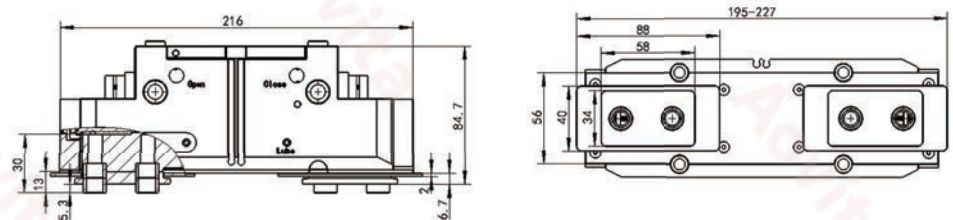



▣ PET-200



■ Gripping force

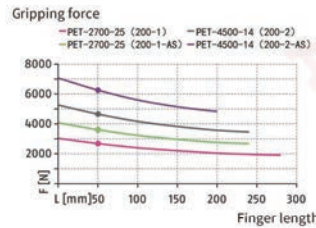

■ Max. load

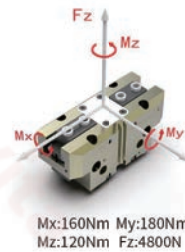

■ Selection

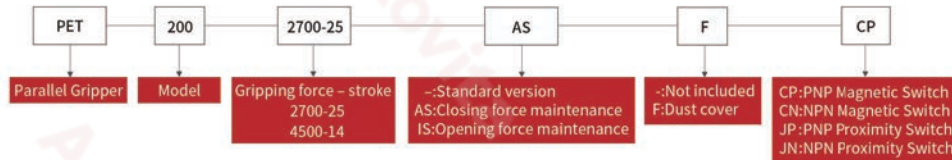

At least two sensors are required for each gripper to detect two positions.

Model	PET-200 2700-25	PET-200 2700-25-AS	PET-200 2700-25-IS	PET-200 4500-14	PET-200 4500-14-AS	PET-200 4500-14-IS
Gripping force(Closing)	2700N	3500N	/	4500N	5300N	/
Gripping force(Opening)	2800N	/	3600N	4800N	/	5600N
Min. spring force	/	800N	800N	/	800N	800N
Bore size	φ99mm	φ99mm	φ99mm	φ99mm	φ99mm	φ99mm
Workpiece weight	13kg	13kg	13kg	20kg	20kg	20kg
Repeat accuracy	0.05mm	0.05mm	0.05mm	0.05mm	0.05mm	0.05mm
Stroke per jaw	25mm	25mm	25mm	14mm	14mm	14mm
Max. finger length	240mm	240mm	240mm	220mm	220mm	220mm
Max. mass per finger	6kg	6kg	6kg	6kg	6kg	6kg
Operating air pressure	0.25-0.8MPa	0.4-0.8MPa	0.4-0.8MPa	0.25-0.8MPa	0.4-0.8MPa	0.4-0.8MPa
Rated working pressure	0.6MPa	0.6MPa	0.6MPa	0.6MPa	0.6MPa	0.6MPa
Closing/opening time	0.35s	0.3s/0.6s	0.6s/0.3s	0.35s	0.3s/0.6s	0.6s/0.3s
IP class	IP40	IP40	IP40	IP40	IP40	IP40
Air consumption per cycle	385ml	495ml	495ml	385ml	495ml	495ml
Weight	5.5kg	7.5kg	7.5kg	5.5kg	7.5kg	7.5kg
Dimensions	234*100*94mm	234*100*141mm	234*100*141mm	234*100*94mm	234*100*141mm	234*100*141mm
Ambient temperature	0-80°C	0-80°C	0-80°C	0-80°C	0-80°C	0-80°C

①The table shows test values at 0.6 MPa. It may take hundreds of gripping cycles to reach the max. gripping force (indicated in the data sheet).

■ Dimensions

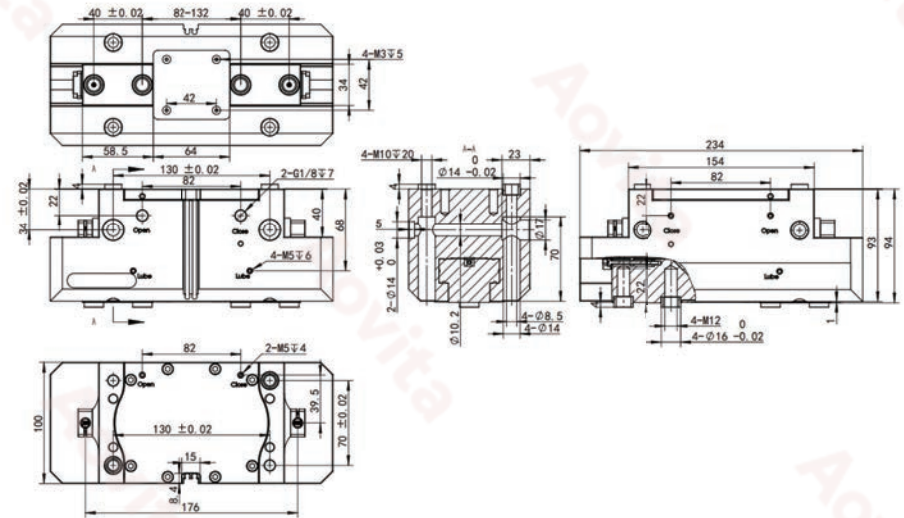

■ Hose-free direct connection

Refer to this connection method for top air supply.

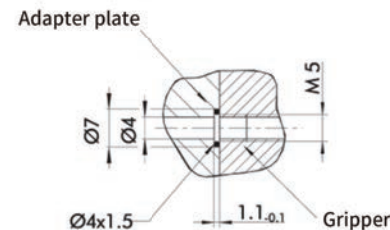

■ Maintenance device(AS/IS)

The gripper maintains minimum gripping force via spring force even if pressure drops. AS: closing force, IS: opening force.

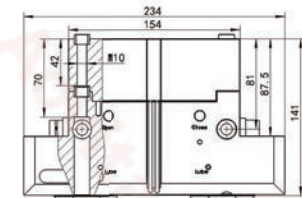

■ Dustproof device(F)

Lube dustproof air port connects to 0.1 MPa positive pressure to achieve IP64.

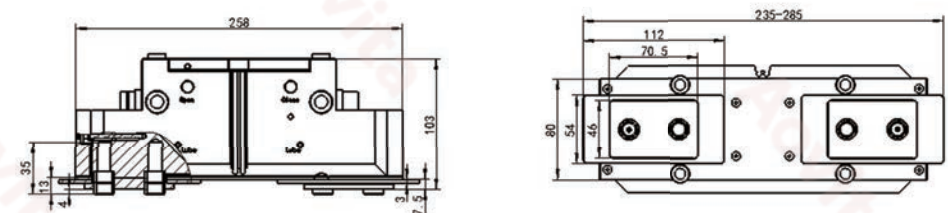



▣ PET-240



■ Gripping force

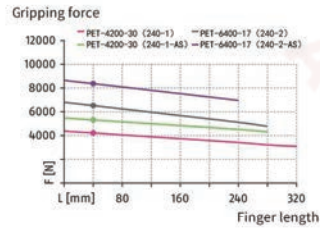

■ Max. load



Mx:240Nm My:230Nm  
Mz:150Nm Fz:6000N

■ Selection

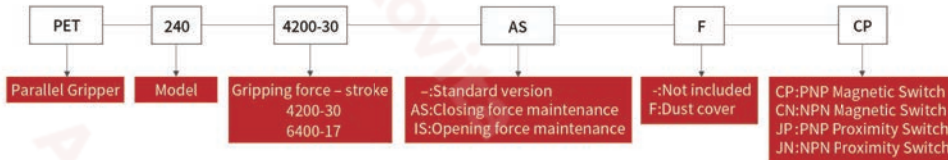

At least two sensors are required for each gripper to detect two positions.

Model	PET-240 4200-30	PET-240 4200-30-AS	PET-240 4200-30-IS	PET-240 6400-17	PET-240 6400-17-AS	PET-240 6400-17-IS
Gripping force(Closing)	4200N	5200N	/	6400N	7400N	/
Gripping force(Opening)	4400N	/	5400N	6700N	/	7700N
Min. spring force	/	1000N	1000N	/	1000N	1000N
Bore size	φ116mm	φ116mm	φ116mm	φ116mm	φ116mm	φ116mm
Workpiece weight	20kg	20kg	20kg	30kg	30kg	30kg
Repeat accuracy	0.05mm	0.05mm	0.05mm	0.05mm	0.05mm	0.05mm
Stroke per jaw	30mm	30mm	30mm	17mm	17mm	17mm
Max. finger length	280mm	280mm	280mm	240mm	240mm	240mm
Max. mass per finger	8kg	8kg	8kg	8kg	8kg	8kg
Operating air pressure	0.25-0.8MPa	0.4-0.8MPa	0.4-0.8MPa	0.25-0.8MPa	0.4-0.8MPa	0.4-0.8MPa
Rated working pressure	0.6MPa	0.6MPa	0.6MPa	0.6MPa	0.6MPa	0.6MPa
Closing/opening time	0.45s	0.4s/0.7s	0.7s/0.4s	0.45s	0.4s/0.7s	0.7s/0.4s
IP class	IP40	IP40	IP40	IP40	IP40	IP40
Air consumption per cycle	650ml	810ml	810ml	650ml	810ml	810ml
Weight	9kg	12kg	12kg	9kg	12kg	12kg
Dimensions	270*115*111mm	270*115*164mm	270*115*164mm	270*115*111mm	270*115*164mm	270*115*164mm
Ambient temperature	0-80°C	0-80°C	0-80°C	0-80°C	0-80°C	0-80°C

①The table shows test values at 0.6 MPa. It may take hundreds of gripping cycles to reach the max. gripping force (indicated in the data sheet).

■ Dimensions

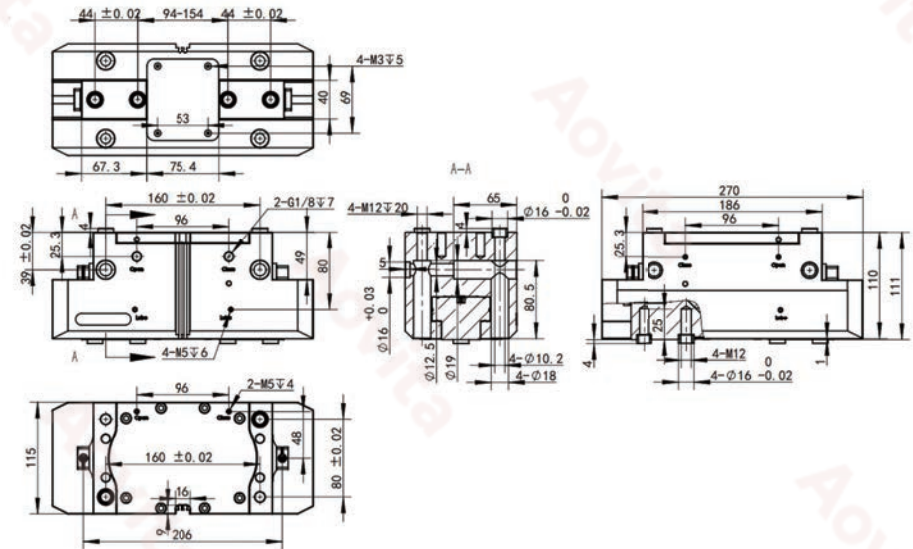

■ Hose-free direct connection

Refer to this connection plate method for top air supply.

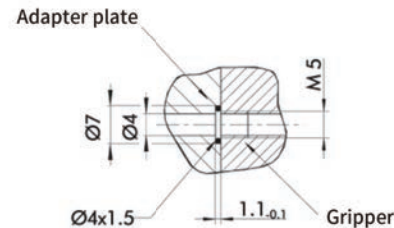

■ Maintenance device(AS/IS)

The gripper maintains minimum gripping force via spring force even if pressure drops. AS: closing force, IS: opening force.

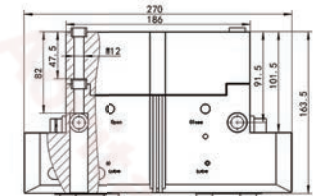

■ Dustproof device(F)

Lube dustproof air port connects to 0.1 MPa positive pressure to achieve IP64.

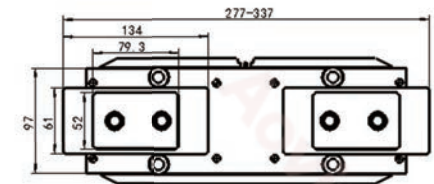
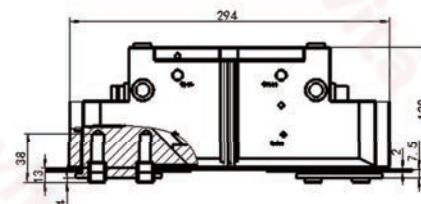

▣ PET-300

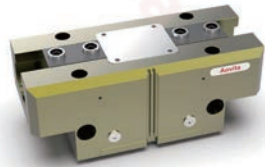

■ Gripping force

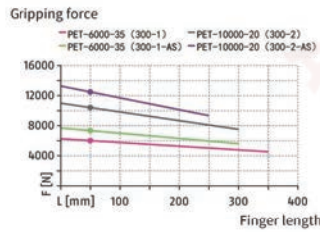

■ Max. load

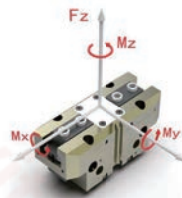

Mx:380Nm My:380Nm  
Mz:240Nm Fz:8000N

■ Selection

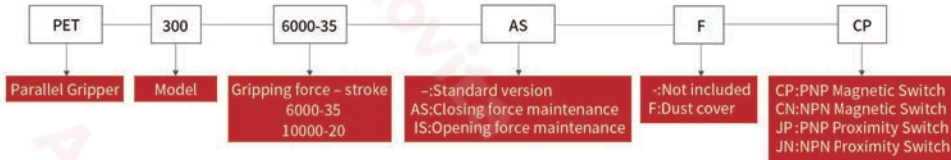

At least two sensors are required for each gripper to detect two positions.

Model	PET-300 6000-35	PET-300 6000-35-AS	PET-300 6000-35-IS	PET-300 10000-20	PET-300 10000-20-AS	PET-300 10000-20-IS
Gripping force(Closing)	6000N	7200N	/	10000N	11200N	/
Gripping force(Opening)	6200N	/	7400N	10500N	/	11700N
Min. spring force	/	1200N	1200N	/	1200N	1200N
Bore size	φ136mm	φ136mm	φ136mm	φ136mm	φ136mm	φ136mm
Workpiece weight	30kg	30kg	30kg	50kg	50kg	50kg
Repeat accuracy	0.05mm	0.05mm	0.05mm	0.05mm	0.05mm	0.05mm
Stroke per jaw	35mm	35mm	35mm	17mm	17mm	17mm
Max. finger length	320mm	300mm	300mm	250mm	250mm	250mm
Max. mass per finger	10kg	10kg	10kg	10kg	10kg	10kg
Operating air pressure	0.25-0.8MPa	0.4-0.8MPa	0.4-0.8MPa	0.25-0.8MPa	0.4-0.8MPa	0.4-0.8MPa
Rated working pressure	0.6MPa	0.6MPa	0.6MPa	0.6MPa	0.6MPa	0.6MPa
Closing/opening time	0.5s	0.4s/0.7s	0.7s/0.4s	0.5s	0.4s/0.7s	0.7s/0.4s
IP class	IP40	IP40	IP40	IP40	IP40	IP40
Air consumption per cycle	1040ml	1295ml	1295ml	1040ml	1295ml	1295ml
Weight	14kg	18kg	18kg	14kg	18kg	18kg
Dimensions	320*140*126	320*140*172	320*140*172	320*140*126	320*140*172	320*140*172
Ambient temperature	0-80°C	0-80°C	0-80°C	0-80°C	0-80°C	0-80°C

① The table shows test values at 0.6 MPa. It may take hundreds of gripping cycles to reach the max. gripping force (indicated in the data sheet).

■ Dimensions

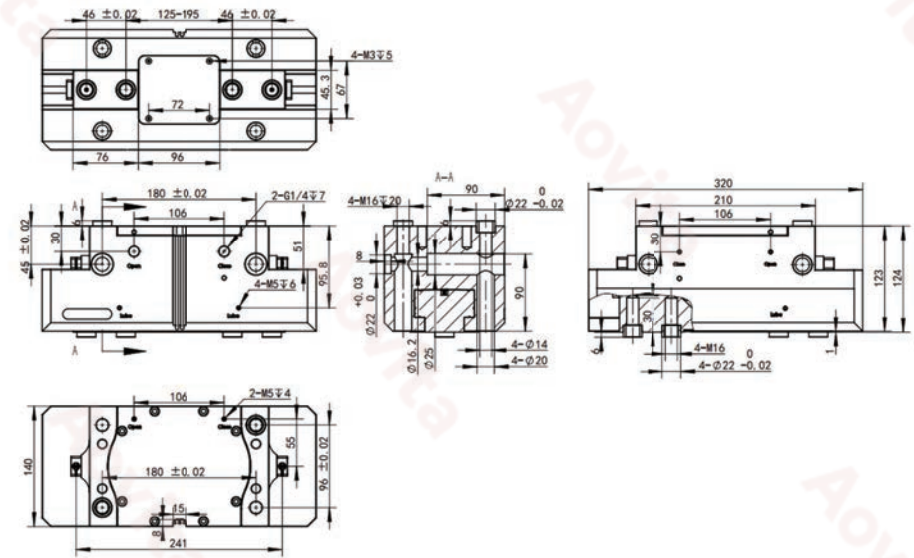

■ Hose-free direct connection

Refer to this connection method for top air supply.

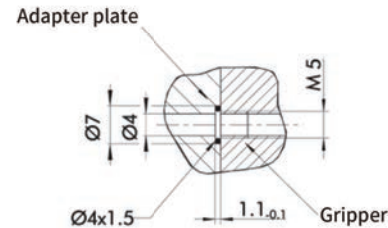

■ Maintenance device(AS/IS)

The gripper maintains minimum gripping force via spring force even if pressure drops. AS: closing force, IS: opening force.

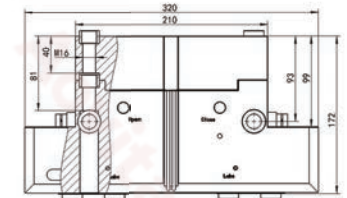

■ Dustproof device(F)

Lube dustproof air port connects to 0.1 MPa positive pressure to achieve IP64.

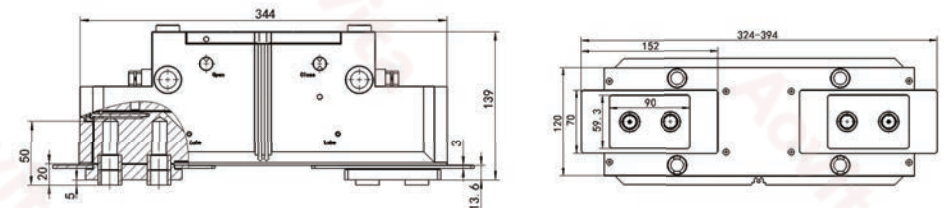



# Aovita PST Centric Gripper

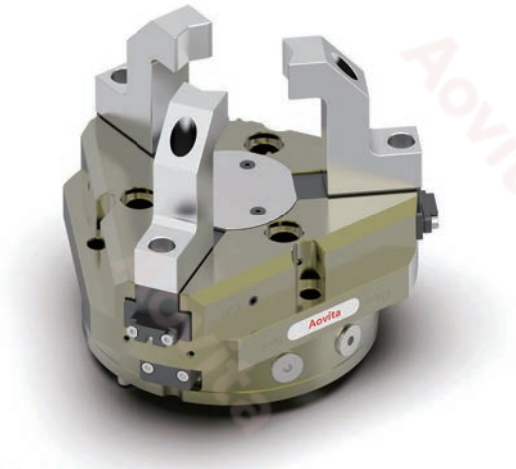

- High payload
- Stable
- Compact design

## Application

Universal solution for multiple industries. Ideal for mechanical engineering, assembly & material handling, and automotive production – in clean to lightly dusty environments.

## Advantages

- ① Robust T-slot guide rail for precise gripping of diverse workpieces.
- ② Comprehensive sensors for versatile querying possibilities and stroke position monitoring.
- ③ Maximum piston surface area for maximum gripping force.
- ④ The wedge-hook design ensures high force transmission and synchronous gripping.
- ⑤ Mounting interfaces on three sides for universal and flexible gripper assembly.
- ⑥ Air supply via hose-free direct connection or screw connections for universal and flexible gripper assembly.



Sizes  
8



Gripper weight  
0.3-24Kg



Gripping force  
300-23700N



Stroke per jaw  
2-30mm



Workpiece weight  
1-100Kg

# Optional Modules

Tailored to industry-specific requirements

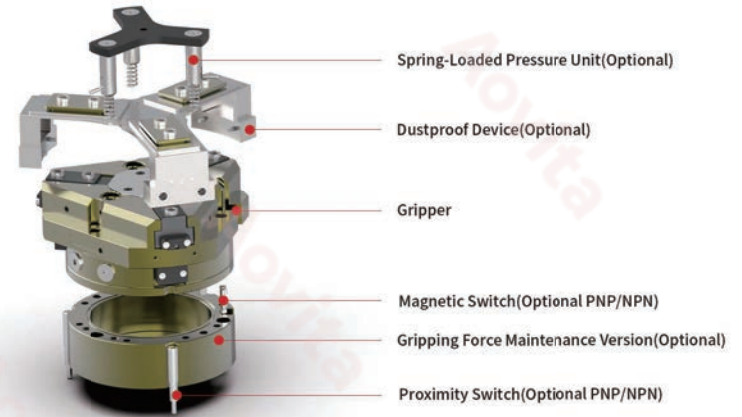

Note: Each gripper requires a minimum of two sensors (one for open position, one for closed position).

Model	Stroke per jaw [mm]	Gripping Force (Closing) [N]	Gripping Force (Opening) [N]	Workpiece weight [kg]	Gripper weight [kg]
PST-50	4	300	320	1.5	0.27
	2	600	640	2.8	0.27
PST-64	6	500	550	2.6	0.46
	3	900	1000	4	0.46
PST-80	8	1000	1080	5	0.9
	4	2000	2200	10	0.9
PST-100	10	1800	1900	9	1.7
	5	3600	3800	18	1.7
PST-125	13	3100	3200	15	2.7
	6	5600	6000	28	2.7
PST-160	16	6000	6200	30	5.5
	8	10000	11000	50	5.5
PST-200	25	7100	7500	35	10
	14	12000	13000	60	10
PST-240	30	9500	10000	50	17
	17	19000	20000	100	17



□ PST-50



■ Gripping force

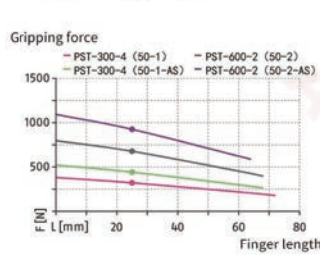

■ Max. load

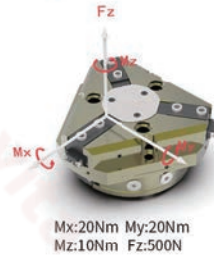

■ Dimensions

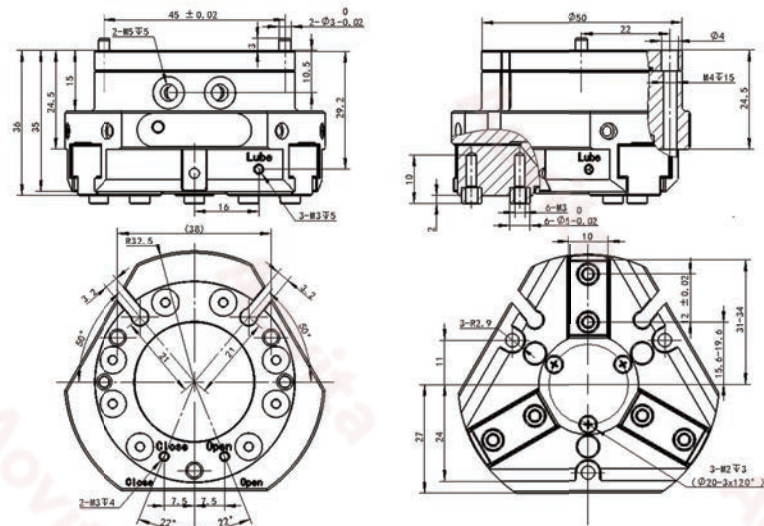

■ Selection

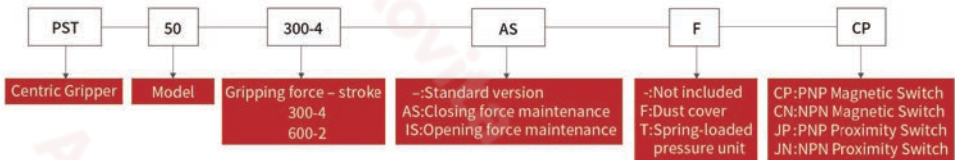

At least two sensors are required for each gripper to detect two positions.

Model	PST-50 300-4	PST-50 300-4-AS	PST-50 300-4-IS	PST-50 600-2	PST-50 600-2-AS	PST-50 600-2-IS
Gripping force(Closing)	300N	400N	/	600N	700N	/
Gripping force(Opening)	320N	/	420N	640N	/	740N
Min. spring force	/	100N	100N	/	100N	100N
Bore size	φ33mm	φ33mm	φ33mm	φ33mm	φ33mm	φ33mm
Workpiece weight	1.5kg	1.5kg	1.5kg	2.8kg	2.8kg	2.8kg
Repeat accuracy	0.02mm	0.02mm	0.02mm	0.02mm	0.02mm	0.02mm
Stroke per jaw	4mm	4mm	4mm	2mm	2mm	2mm
Max. finger length	70mm	70mm	70mm	60mm	60mm	60mm
Max. mass per finger	0.18kg	0.18kg	0.18kg	0.18kg	0.18kg	0.18kg
Operating air pressure	0.3-0.8MPa	0.4-0.8MPa	0.4-0.8MPa	0.3-0.8MPa	0.4-0.8MPa	0.4-0.8MPa
Rated working pressure	0.6MPa	0.6MPa	0.6MPa	0.6MPa	0.6MPa	0.6MPa
Closing/opening time	0.03s	0.02s/0.04s	0.04s/0.02s	0.03s	0.02s/0.04s	0.04s/0.02s
IP class	IP40	IP40	IP40	IP40	IP40	IP40
Air consumption per cycle	9ml	18ml	18ml	9ml	18ml	18ml
Weight	0.27kg	0.35kg	0.35kg	0.27kg	0.35kg	0.35kg
Dimensions	φ65*36mm	φ65*47mm	φ65*47mm	φ65*36mm	φ65*47mm	φ65*47mm
Ambient temperature	0-80°C	0-80°C	0-80°C	0-80°C	0-80°C	0-80°C

①The table shows test values at 0.6 MPa. It may take hundreds of gripping cycles to reach the max. gripping force (indicated in the data sheet).

■ Spring-loaded pressure unit(T)

Stroke: 4 mm Minimum Thrust: 11 N

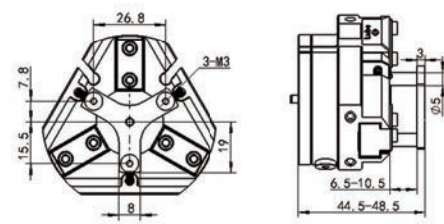

■ Maintenance device(AS/IS)

The gripper maintains minimum gripping force via spring force even if pressure drops. AS: closing force, IS: opening force.

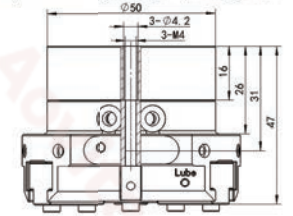

■ Dustproof device(F)

Lube dustproof air port connects to 0.1 MPa positive pressure to achieve IP64.

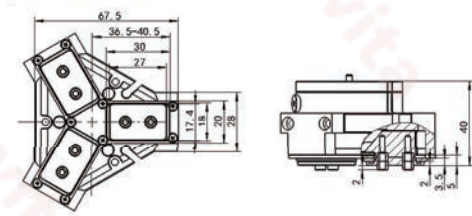

■ Hose-free direct connection

Refer to this connection method for top air supply.

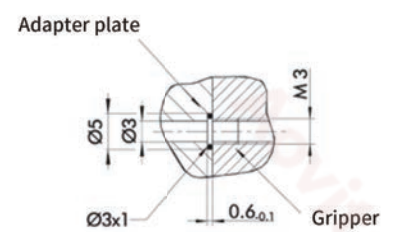

▣ PST-64



■ Gripping force

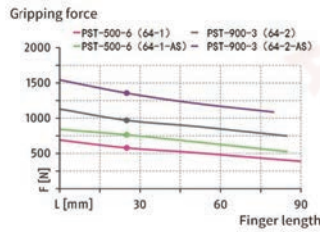

■ Max. load

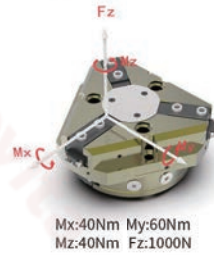

■ Dimensions

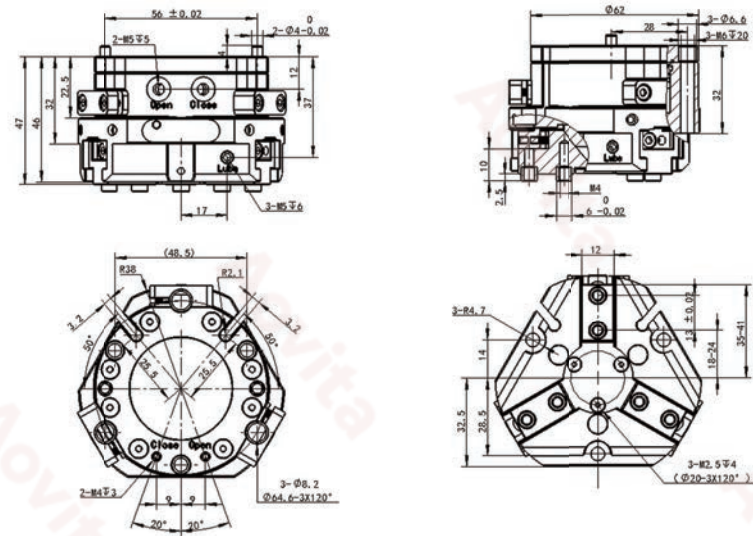

■ Selection

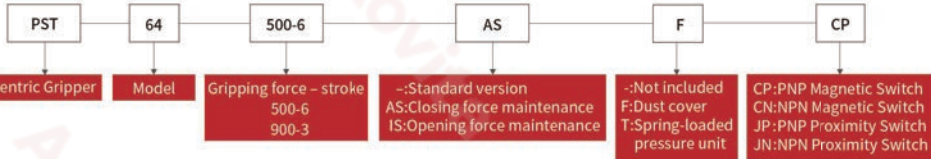

At least two sensors are required for each gripper to detect two positions.

Model	PST-64 500-6	PST-64 500-6-AS	PST-64 500-6-IS	PST-64 900-3	PST-64 900-3-AS	PST-64 900-3-IS
Gripping force(Closing)	500N	650N	/	900N	1050N	/
Gripping force(Opening)	550N	/	700N	1000N	/	1150N
Min. spring force	/	150N	150N	/	150N	150N
Bore size	φ43mm	φ43mm	φ43mm	φ43mm	φ43mm	φ43mm
Workpiece weight	2.6kg	2.5kg	2.6kg	4kg	4kg	4kg
Repeat accuracy	0.02mm	0.02mm	0.02mm	0.02mm	0.02mm	0.02mm
Stroke per jaw	6mm	6mm	6mm	3mm	3mm	3mm
Max. finger length	90mm	90mm	90mm	80mm	80mm	80mm
Max. mass per finger	0.3kg	0.3kg	0.3kg	0.3kg	0.3kg	0.3kg
Operating air pressure	0.3-0.8MPa	0.4-0.8MPa	0.4-0.8MPa	0.3-0.8MPa	0.4-0.8MPa	0.4-0.8MPa
Rated working pressure	0.6MPa	0.6MPa	0.6MPa	0.6MPa	0.6MPa	0.6MPa
Closing/opening time	0.03s	0.02s/0.04s	0.04s/0.02s	0.03s	0.02s/0.04s	0.04s/0.02s
IP class	IP40	IP40	IP40	IP40	IP40	IP40
Air consumption per cycle	25ml	48ml	48ml	25ml	48ml	48ml
Weight	0.5kg	0.5kg	0.6kg	0.5kg	0.6kg	0.6kg
Dimensions	φ76*47mm	φ76*61mm	φ76*61mm	φ76*47mm	φ76*61mm	φ76*61mm
Ambient temperature	0-80°C	0-80°C	0-80°C	0-80°C	0-80°C	0-80°C

①The table shows test values at 0.6 MPa. It may take hundreds of gripping cycles to reach the max. gripping force (indicated in the data sheet).

■ Spring-loaded pressure unit(T)

Stroke: 4 mm Minimum Thrust: 11 N

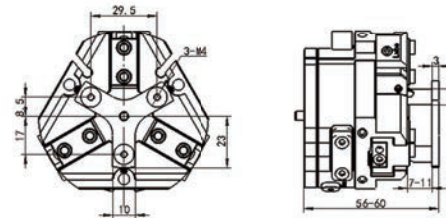

■ Maintenance device(AS/IS)

The gripper maintains minimum gripping force via spring force even if pressure drops. AS: closing force, IS: opening force.

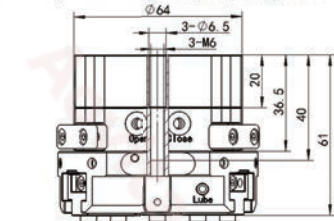

■ Dustproof device(F)

Lube dustproof air port connects to 0.1 MPa positive pressure to achieve IP64.

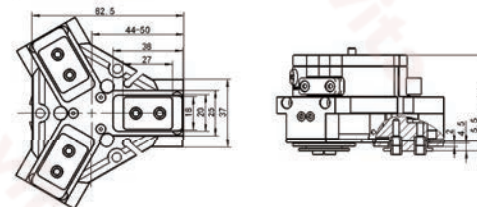

■ Hose-free direct connection

Refer to this connection method for top air supply.

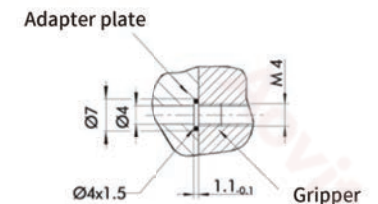



▣ PST-80

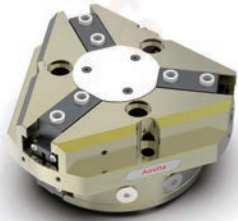

■ Gripping force

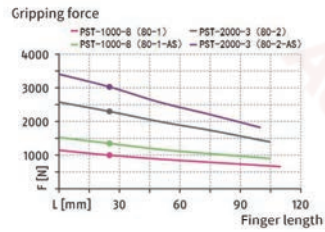

■ Max. load



■ Dimensions

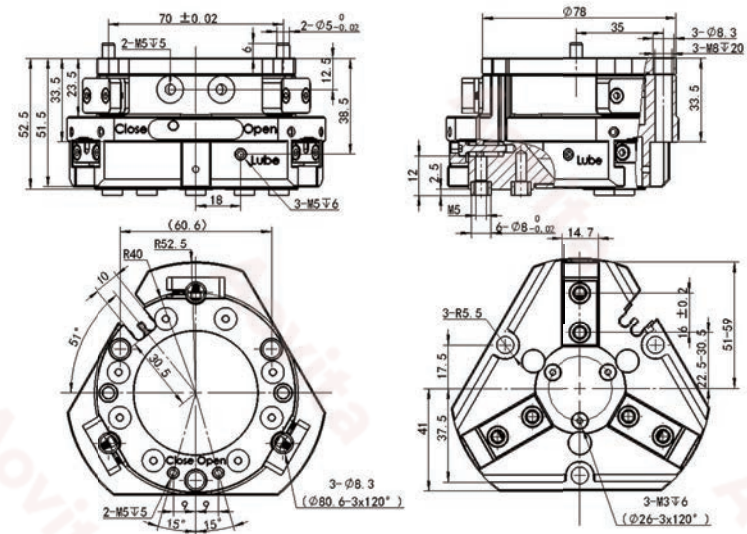

■ Selection

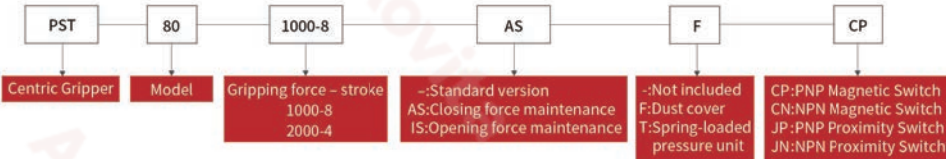

At least two sensors are required for each gripper to detect two positions.

Model	PST-80 1000-8	PST-80 1000-8-AS	PST-80 1000-8-IS	PST-80 2000-4	PST-80 2000-4-AS	PST-80 2000-4-IS
Gripping force(Closing)	1000N	1300N	/	2000N	2300N	/
Gripping force(Opening)	1080N	/	1380N	2200N	/	2500N
Min. spring force	/	300N	300N	/	300N	300N
Bore size	φ55mm	φ55mm	φ55mm	φ55mm	φ55mm	φ55mm
Workpiece weight	5kg	5kg	5kg	10kg	10kg	10kg
Repeat accuracy	0.05mm	0.05mm	0.05mm	0.05mm	0.05mm	0.05mm
Stroke per jaw	8mm	8mm	8mm	4mm	4mm	4mm
Max. finger length	110mm	110mm	110mm	100mm	100mm	100mm
Max. mass per finger	0.6kg	0.5kg	0.6kg	0.6kg	0.6kg	0.6kg
Operating air pressure	0.3-0.8MPa	0.4-0.8MPa	0.4-0.8MPa	0.3-0.8MPa	0.4-0.8MPa	0.4-0.8MPa
Rated working pressure	0.6MPa	0.6MPa	0.6MPa	0.6MPa	0.6MPa	0.6MPa
Closing/opening time	0.05s	0.04s/0.06s	0.06s/0.04s	0.05s	0.04s/0.06s	0.06s/0.04s
IP class	IP40	IP40	IP40	IP40	IP40	IP40
Air consumption per cycle	60ml	110ml	110ml	60ml	110ml	110ml
Weight	0.9kg	1.1kg	1.1kg	0.9kg	1.1kg	1.1kg
Dimensions	Φ105*52.5mm	Φ105*70mm	Φ105*70mm	Φ105*52.5mm	Φ105*70mm	Φ105*70mm
Ambient temperature	0-80°C	0-80°C	0-80°C	0-80°C	0-80°C	0-80°C

①The table shows test values at 0.6 MPa. It may take hundreds of gripping cycles to reach the max. gripping force (indicated in the data sheet).

■ Spring-loaded pressure unit(T)

Stroke: 5 mm Minimum Thrust: 18 N

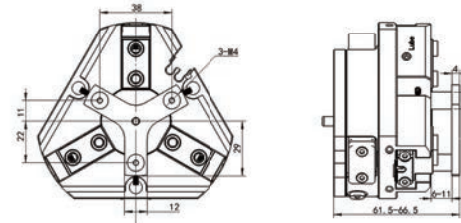

■ Maintenance device(AS/IS)

The gripper maintains minimum gripping force via spring force even if pressure drops. AS: closing force, IS: opening force.

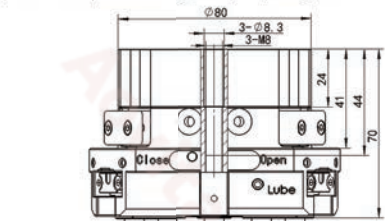

■ Dustproof device(F)

Lube dustproof air port connects to 0.1 MPa positive pressure to achieve IP64.

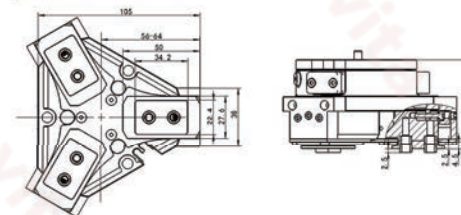

■ Hose-free direct connection

Refer to this connection method for top air supply.

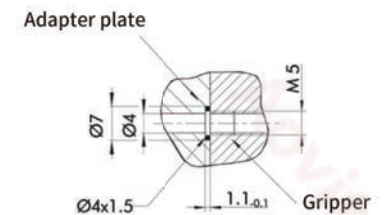



□ PST-100

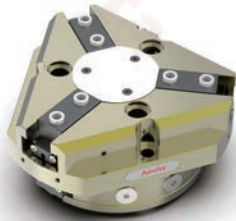

■ Gripping force

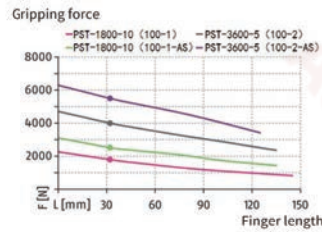

■ Max. load



■ Dimensions

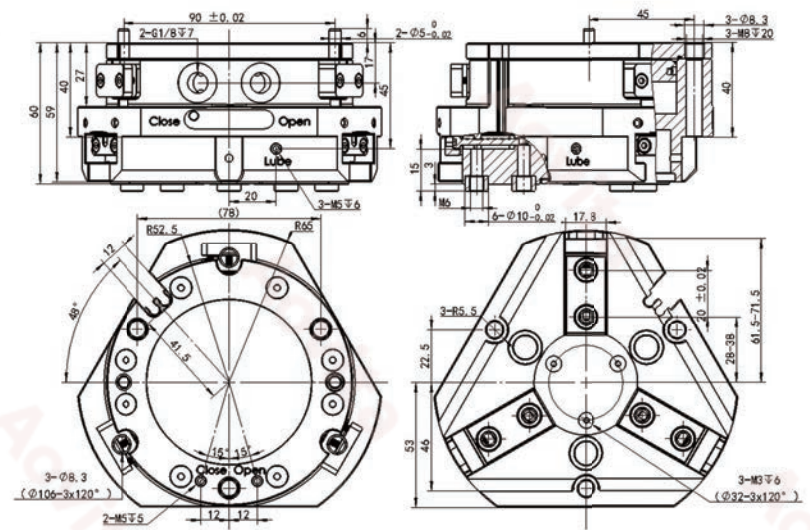

■ Selection

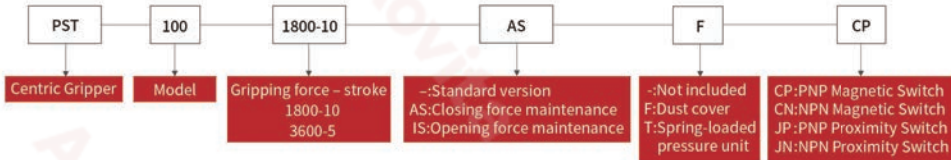

At least two sensors are required for each gripper to detect two positions.

Model	PST-100 1800-10	PST-100 1800-10-AS	PST-100 1800-10-IS	PST-100 3600-5	PST-100 3600-5-AS	PST-100 3600-5-IS
Gripping force(Closing)	1800N	2400N	/	3600N	4200N	/
Gripping force(Opening)	1900N	/	2500N	3800N	/	4400N
Min. spring force	/	600N	600N	/	600N	600N
Bore size	φ75mm	φ75mm	φ75mm	φ75mm	φ75mm	φ75mm
Workpiece weight	9kg	9kg	9kg	18kg	18kg	18kg
Repeat accuracy	0.05mm	0.05mm	0.05mm	0.05mm	0.05mm	0.05mm
Stroke per jaw	10mm	10mm	10mm	5mm	5mm	5mm
Max. finger length	125mm	125mm	125mm	110mm	110mm	110mm
Max. mass per finger	1.1kg	1.1kg	1.1kg	1.1kg	1.1kg	1.1kg
Operating air pressure	0.3-0.8MPa	0.4-0.8MPa	0.4-0.8MPa	0.3-0.8MPa	0.4-0.8MPa	0.4-0.8MPa
Rated working pressure	0.6MPa	0.6MPa	0.6MPa	0.6MPa	0.6MPa	0.6MPa
Closing/opening time	0.1s	0.1s/0.2s	0.2s/0.1s	0.1s	0.1s/0.2s	0.2s/0.1s
IP class	IP40	IP40	IP40	IP40	IP40	IP40
Air consumption per cycle	120ml	210ml	210ml	120ml	210ml	210ml
Weight	1.7kg	3kg	3kg	1.7kg	3kg	3kg
Dimensions	φ130*60mm	φ130*85mm	φ130*85mm	φ130*60mm	φ130*85mm	φ130*85mm
Ambient temperature	0-80°C	0-80°C	0-80°C	0-80°C	0-80°C	0-80°C

①The table shows test values at 0.6 MPa. It may take hundreds of gripping cycles to reach the max. gripping force (indicated in the data sheet).

■ Spring-loaded pressure unit(T)

Stroke: 5.5 mm Minimum Thrust: 35 N

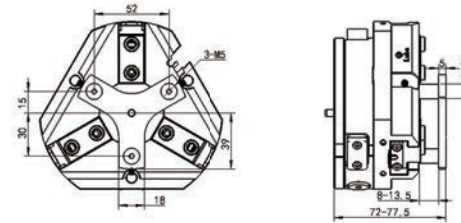

■ Maintenance device(AS/IS)

The gripper maintains minimum gripping force via spring force even if pressure drops. AS: closing force, IS: opening force.

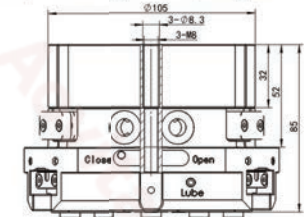

■ Dustproof device(F)

Lube dustproof air port connects to 0.1 MPa positive pressure to achieve IP64.

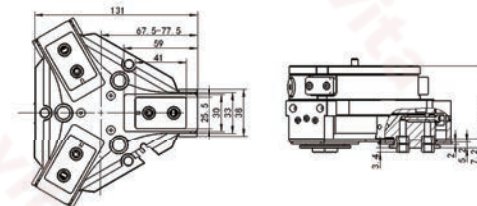

■ Hose-free direct connection

Refer to this connection method for top air supply.

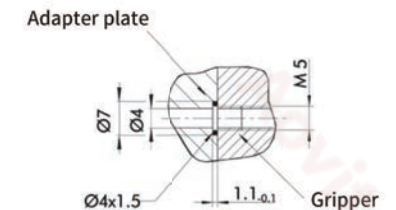

□ PST-125

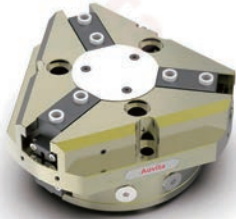

■ Gripping force

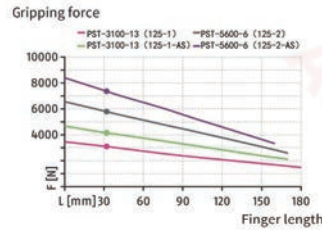

■ Max. load

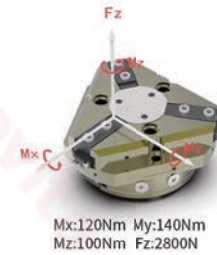

■ Dimensions

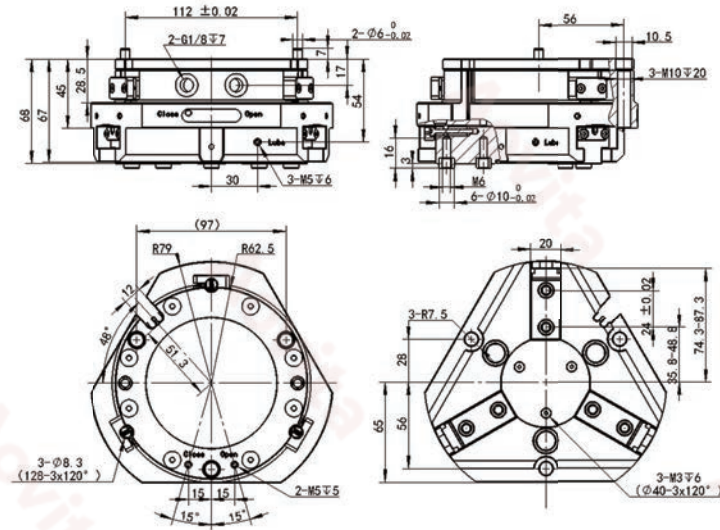

■ Selection

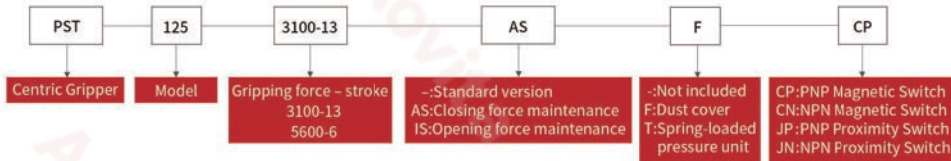

At least two sensors are required for each gripper to detect two positions.

Model	PST-125 3100-13	PST-125 3100-13-AS	PST-125 3100-13-IS	PST-125 5600-6	PST-125 5600-6-AS	PST-125 5600-6-IS
Gripping force(Closing)	3100N	4000N	/	5600N	6500N	/
Gripping force(Opening)	3200N	/	4100N	6000N	/	6900N
Min. spring force	/	900N	900N	/	900N	900N
Bore size	φ94.5mm	φ94.5mm	φ94.5mm	φ94.5mm	φ94.5mm	φ94.5mm
Workpiece weight	15kg	15kg	15kg	28kg	28kg	28kg
Repeat accuracy	0.05mm	0.05mm	0.05mm	0.05mm	0.05mm	0.05mm
Stroke per jaw	13mm	13mm	13mm	6mm	6mm	6mm
Max. finger length	170mm	170mm	170mm	160mm	160mm	160mm
Max. mass per finger	2kg	2kg	2kg	2kg	2kg	2kg
Operating air pressure	0.3-0.8MPa	0.4-0.8MPa	0.4-0.8MPa	0.3-0.8MPa	0.4-0.8MPa	0.4-0.8MPa
Rated working pressure	0.6MPa	0.6MPa	0.6MPa	0.6MPa	0.6MPa	0.6MPa
Closing/opening time	0.2s	0.18s/0.35s	0.35s/0.18s	0.2s	0.18s/0.35s	0.35s/0.18s
IP class	IP40	IP40	IP40	IP40	IP40	IP40
Air consumption per cycle	230ml	390ml	390ml	230ml	390ml	390ml
Weight	2.7kg	3.4kg	3.4kg	2.7kg	3.4kg	3.4kg
Dimensions	φ160*97mm	φ160*97mm	φ160*97mm	φ160*97mm	φ160*97mm	φ160*97mm
Ambient temperature	0-80°C	0-80°C	0-80°C	0-80°C	0-80°C	0-80°C

①The table shows test values at 0.6 MPa. It may take hundreds of gripping cycles to reach the max. gripping force (indicated in the data sheet).

■ Spring-loaded pressure unit(T)

Stroke: 6 mm Minimum Thrust: 105N

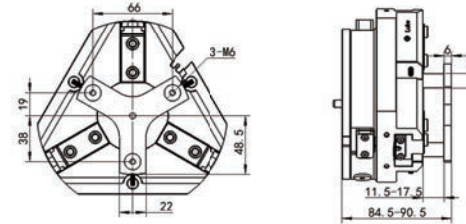

■ Maintenance device(AS/IS)

The gripper maintains minimum gripping force via spring force even if pressure drops. AS: closing force, IS: opening force.

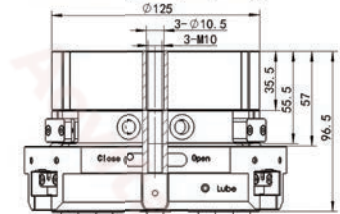

■ Dustproof device(F)

Lube dustproof air port connects to 0.1 MPa positive pressure to achieve IP64.

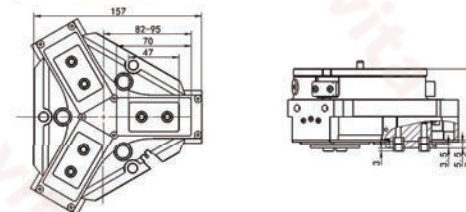

■ Hose-free direct connection

Refer to this connection method for top air supply.

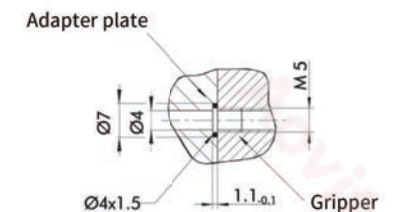



□ PST-160

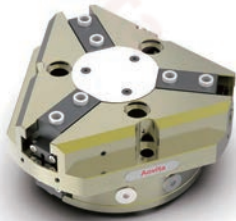

■ Gripping force

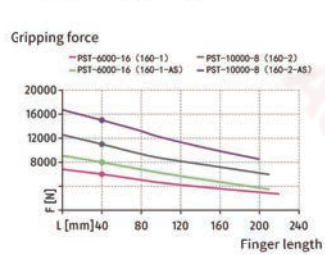

■ Max. load

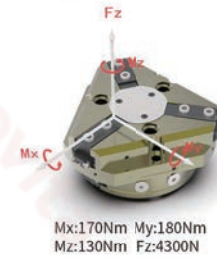

■ Dimensions

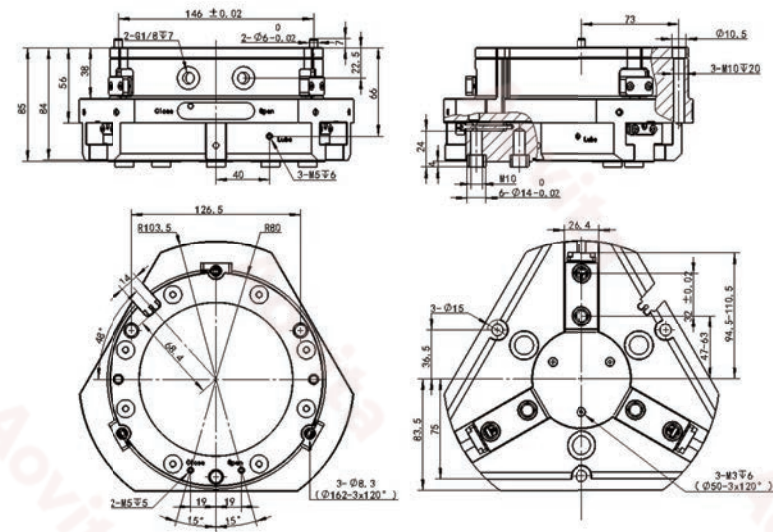

■ Selection

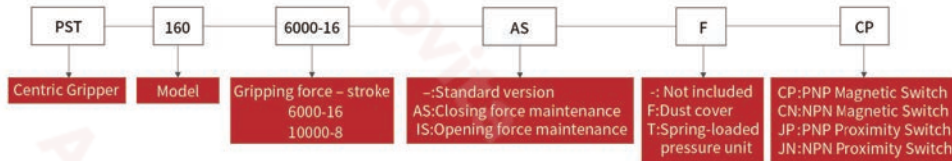

At least two sensors are required for each gripper to detect two positions.

Model	PST-160 6000-16	PST-160 6000-16-AS	PST-160 6000-16-IS	PST-160 10000-8	PST-160 10000-8-AS	PST-160 10000-8-IS
Gripping force(Closing)	6000N	7600N	/	10000N	11600N	/
Gripping force(Opening)	6200N	/	7800N	11000N	/	12600N
Min. spring force	/	1600N	1600N	/	1600N	1600N
Bore size	φ130mm	φ130mm	φ130mm	φ130mm	φ130mm	φ130mm
Workpiece weight	30kg	30kg	30kg	50kg	50kg	50kg
Repeat accuracy	0.05mm	0.05mm	0.05mm	0.05mm	0.05mm	0.05mm
Stroke per jaw	16mm	16mm	16mm	8mm	8mm	8mm
Max. finger length	200mm	200mm	200mm	180mm	180mm	180mm
Max. mass per finger	3kg	3kg	3kg	3kg	3kg	3kg
Operating air pressure	0.3-0.8MPa	0.4-0.8MPa	0.4-0.8MPa	0.3-0.8MPa	0.4-0.8MPa	0.4-0.8MPa
Rated working pressure	0.6MPa	0.6MPa	0.6MPa	0.6MPa	0.6MPa	0.6MPa
Closing/opening time	0.5s	0.4s/0.8s	0.8s/0.4s	0.5s	0.4s/0.8s	0.8s/0.4s
IP class	IP40	IP40	IP40	IP40	IP40	IP40
Air consumption per cycle	550ml	900ml	900ml	550ml	900ml	900ml
Weight	5.5kg	7.5kg	7.5kg	5.5kg	7.5kg	7.5kg
Dimensions	φ207*85mm	φ207*121mm	φ207*121mm	φ207*85mm	φ207*121mm	φ207*121mm
Ambient temperature	0-80°C	0-80°C	0-80°C	0-80°C	0-80°C	0-80°C

①The table shows test values at 0.6 MPa. It may take hundreds of gripping cycles to reach the max. gripping force (indicated in the data sheet).

■ Spring-loaded pressure unit(T)

Stroke: 6.5 mm Minimum Thrust: 150N

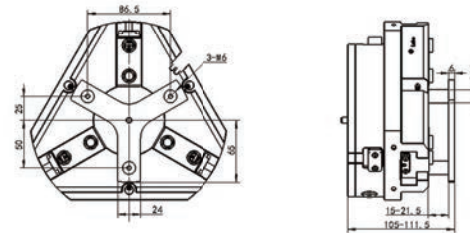

■ Maintenance device(AS/IS)

The gripper maintains minimum gripping force via spring force even if pressure drops. AS: closing force, IS: opening force.

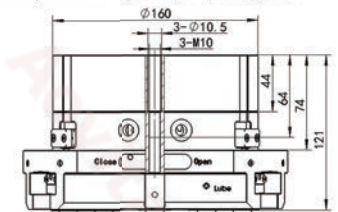

■ Dustproof device(F)

Lube dustproof air port connects to 0.1 MPa positive pressure to achieve IP64.

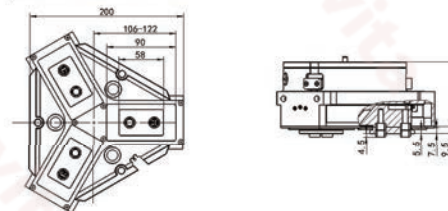

■ Hose-free direct connection

Refer to this connection method for top air supply.

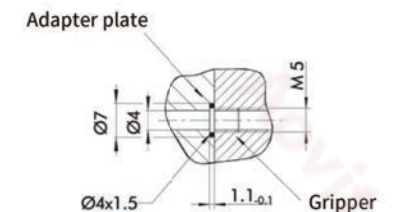

□ PST-200



■ Gripping force

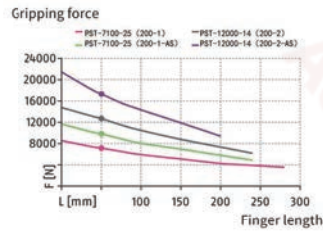

■ Max. load

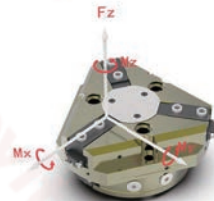

Mx:180Nm My:200Nm  
Mz:140Nm Fz:5000N

■ Dimensions

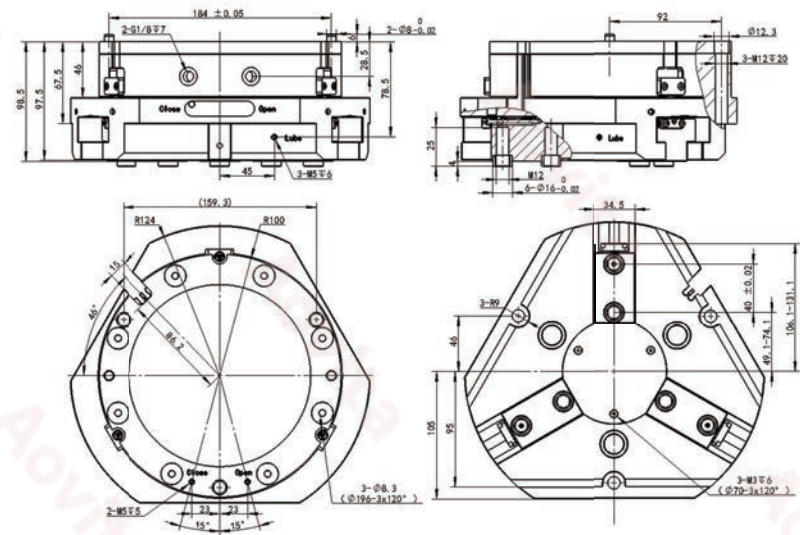

■ Selection

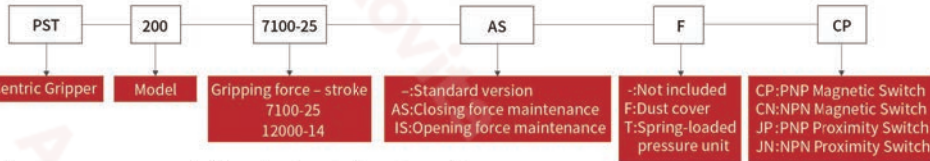

At least two sensors are required for each gripper to detect two positions.

Model	PST-200 7100-25	PST-200 7100-25-AS	PST-200 7100-25-IS	PST-200 12000-14	PST-200 12000-14-AS	PST-200 12000-14-IS
Gripping force(Closing)	7100N	9300N	/	12000N	14200N	/
Gripping force(Opening)	7500N	/	9700N	13000N	/	15200N
Min. spring force	/	2200N	2200N	/	2200N	2200N
Bore size	φ165mm	φ165mm	φ165mm	φ165mm	φ165mm	φ165mm
Workpiece weight	35kg	35kg	35kg	60kg	60kg	60kg
Repeat accuracy	0.05mm	0.05mm	0.05mm	0.05mm	0.05mm	0.05mm
Stroke per jaw	25mm	25mm	25mm	14mm	14mm	14mm
Max. finger length	240mm	240mm	240mm	200mm	200mm	200mm
Max. mass per finger	6kg	6kg	6kg	6kg	6kg	6kg
Operating air pressure	0.3-0.8MPa	0.4-0.8MPa	0.4-0.8MPa	0.3-0.8MPa	0.4-0.8MPa	0.4-0.8MPa
Rated working pressure	0.6MPa	0.6MPa	0.6MPa	0.6MPa	0.6MPa	0.6MPa
Closing/opening time	1.2s	1s/1.5s	1.5s/1s	1.2s	1s/1.5s	1.5s/1s
IP class	IP40	IP40	IP40	IP40	IP40	IP40
Air consumption per cycle	1050ml	1750ml	1750ml	1050ml	1750ml	1750ml
Weight	10kg	13kg	13kg	10kg	13kg	13kg
Dimensions	φ250*100mm	φ250*138mm	φ250*138mm	φ250*100mm	φ250*138mm	φ250*138mm
Ambient temperature	0-80°C	0-80°C	0-80°C	0-80°C	0-80°C	0-80°C

① The table shows test values at 0.6 MPa. It may take hundreds of gripping cycles to reach the max. gripping force (indicated in the data sheet).

■ Spring-loaded pressure unit(T)

Stroke: 6 mm Minimum Thrust: 200N

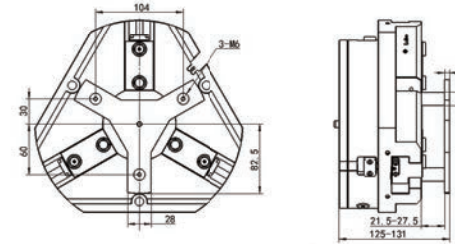

■ Maintenance device(AS/IS)

The gripper maintains minimum gripping force via spring force even if pressure drops. AS: closing force, IS: opening force.

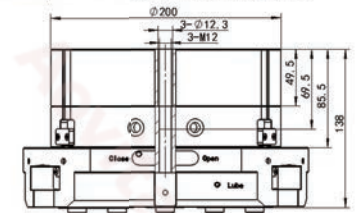

■ Dustproof device(F)

Lube dustproof air port connects to 0.1 MPa positive pressure to achieve IP64.

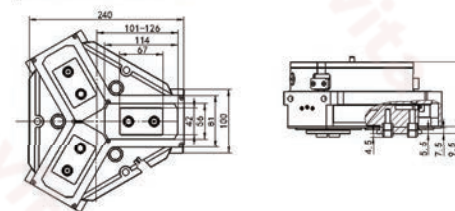

■ Hose-free direct connection

Refer to this connection method for top air supply.

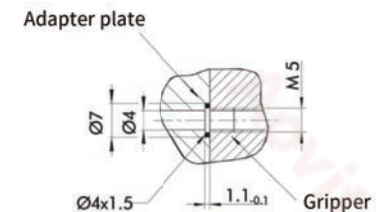



□ PST-240



■ Gripping force

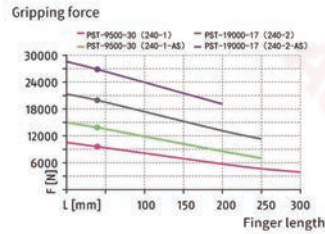

■ Max. load

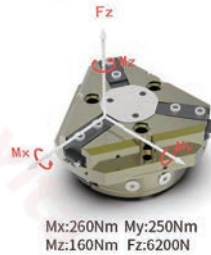

■ Dimensions

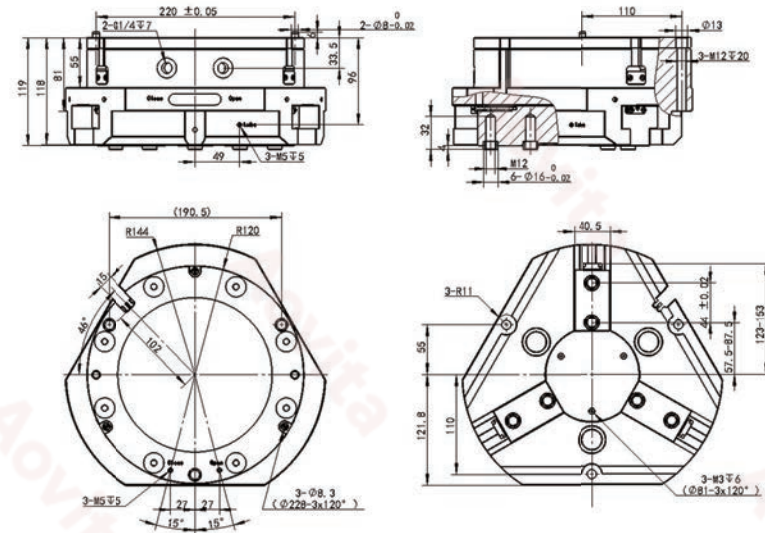

■ Selection

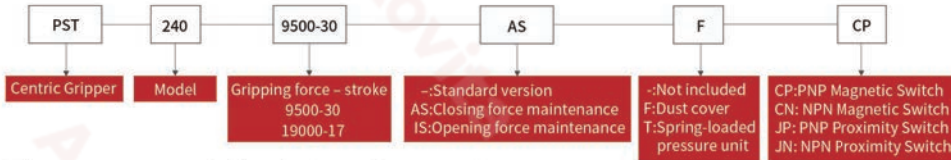

At least two sensors are required for each gripper to detect two positions.

Model	PST-240 9500-30	PST-240 9500-30-AS	PST-240 9500-30-IS	PST-240 19000-17	PST-240 19000-17-AS	PST-240 19000-17-IS
Gripping force(Closing)	9500N	13200N	/	19000N	22700N	/
Gripping force(Opening)	10000N	/	13700N	20000N	/	23700N
Min. spring force	/	3700N	3700N	/	3700N	3700N
Bore size	φ195mm	φ195mm	φ195mm	φ195mm	φ195mm	φ195mm
Workpiece weight	50kg	50kg	50kg	100kg	100kg	100kg
Repeat accuracy	0.05mm	0.05mm	0.05mm	0.05mm	0.05mm	0.05mm
Stroke per jaw	30mm	30mm	30mm	17mm	17mm	17mm
Max. finger length	250mm	250mm	250mm	200mm	200mm	200mm
Max. mass per finger	8kg	8kg	8kg	8kg	8kg	8kg
Operating air pressure	0.3-0.8MPa	0.4-0.8MPa	0.4-0.8MPa	0.3-0.8MPa	0.4-0.8MPa	0.4-0.8MPa
Rated working pressure	0.6MPa	0.6MPa	0.6MPa	0.6MPa	0.6MPa	0.6MPa
Closing/opening time	1.3s	1.1s/2.1s	2.1s/1.1s	1.3s	1.1s/2.1s	2.1s/1.1s
IP class	IP40	IP40	IP40	IP40	IP40	IP40
Air consumption per cycle	1800ml	3100ml	3100ml	1800ml	3100ml	3100ml
Weight	17kg	24kg	24kg	17kg	24kg	24kg
Dimensions	φ290*129mm	φ290*179mm	φ290*179mm	φ290*129mm	φ290*179mm	φ290*179mm
Ambient temperature	0-80°C	0-80°C	0-80°C	0-80°C	0-80°C	0-80°C

①The table shows test values at 0.6 MPa. It may take hundreds of gripping cycles to reach the max. gripping force (indicated in the data sheet).

■ Spring-loaded pressure unit(T)

Stroke: 7.5 mm Minimum Thrust: 240N

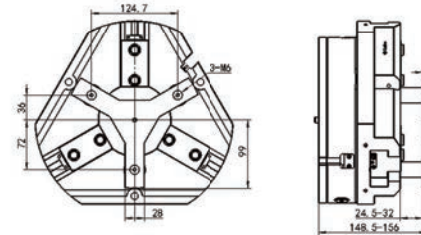

■ Maintenance device(AS/IS)

The gripper maintains minimum gripping force via spring force even if pressure drops. AS: closing force, IS: opening force.

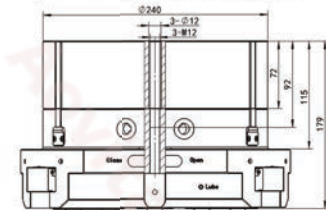

■ Dustproof device(F)

Lube dustproof air port connects to 0.1 MPa positive pressure to achieve IP64.

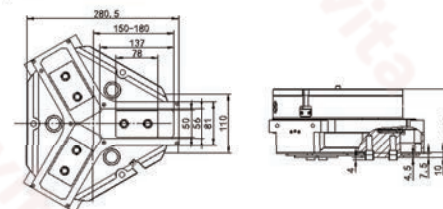

■ Hose-free direct connection

Refer to this connection method for top air supply.

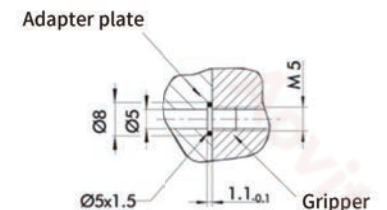

## Aovita ARU Rotary Unit



- Flexible
- Powerful
- Precise

### ■ Application

180° turnover robot solution for press loading/unloading.

### ■ Advantages

- ① High-performance hydraulic shock absorbers for excellent energy absorption even under heavy payloads.
- ② Hose-free direct connection and air circuit integrated into the swivel unit.
- ③ Large center hole for electrical wiring and twist-free operation.
- ④ Standard gripper- engineered for durability and precision.

## Optional Modules

Tailored to industry-specific requirements



Model	Bore size [mm]	Theoretical torque [Nm]	Recommended workpiece weight per jaw [kg]
ARU-20	20	3	1.5
ARU-25	25	5	3
ARU-30	30	10	5
ARU-40	40	40	10



ARU-20



Selection

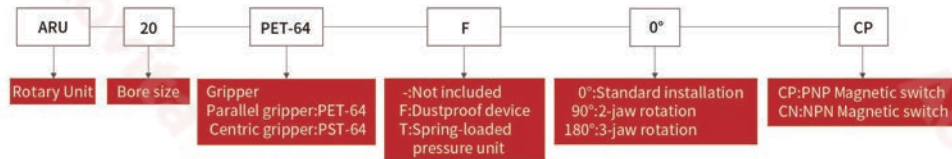

Each rotary unit requires two sensors. Each gripper requires a minimum of two sensors(one for open position, one for closed position).

Model	ARU-20	Model	PET-64	Model	PST-64
Theoretical torque	3Nm	Gripping force(closed)	200N	Gripping force(closed)	500N
Swivel angle	180°	Gripping force(open)	240N	Gripping force(open)	550N
Bore size	φ20mm	Workpiece weight	1kg	Workpiece weight	1.5kg
Shock absorber	Hydraulic shock absorber	Repeatability	0.02mm	Repeatability	0.02mm
Repeatability	0.02mm	Stroke per jaw	6mm	Stroke per jaw	6mm
Operating pressure	0.3-0.8MPa	Max. finger length	90mm	Max. finger length	90mm
Nominal pressure	0.6MPa	Max. weight per finger	0.3kg	Max. weight per finger	0.3kg
IP class	IP40	Operating pressure	0.3-0.8MPa	Operating pressure	0.3-0.8MPa
Air consumption	75ml per cycle	Nominal pressure	0.6MPa	Nominal pressure	0.6MPa
Weight	2kg	IP class	IP40	IP class	IP40
Operating temperature	0-80°C	Operating temperature	0-80°C	Operating temperature	0-80°C

Dimensions

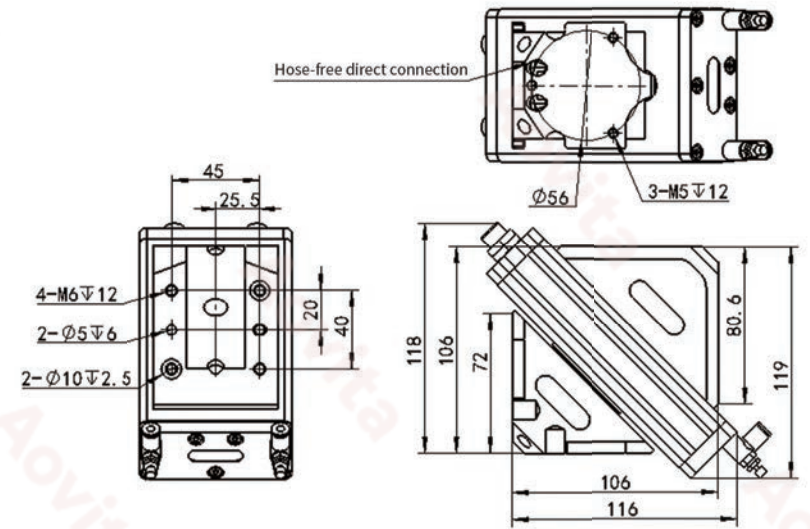

Mounting Options

Centric gripper - 0°

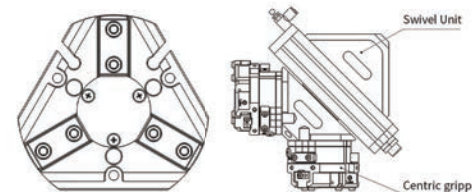

Centric gripper - 180° rotated

Adapter plates available in various thicknesses to suit different requirements.

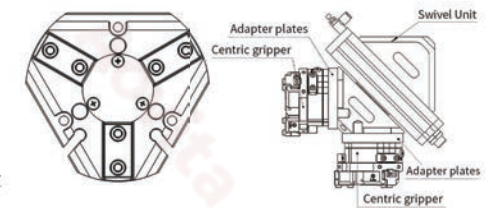

Parallel gripper - 0°

Adapter plates available in various thicknesses to suit different requirements.

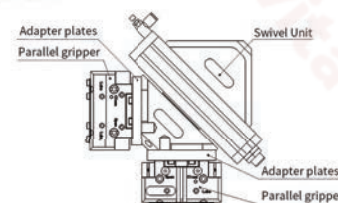

Parallel gripper - 90° rotated

Adapter plates available in various thicknesses to suit different requirements.

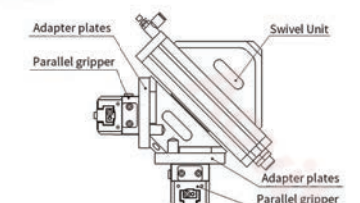

ARU-25



Selection

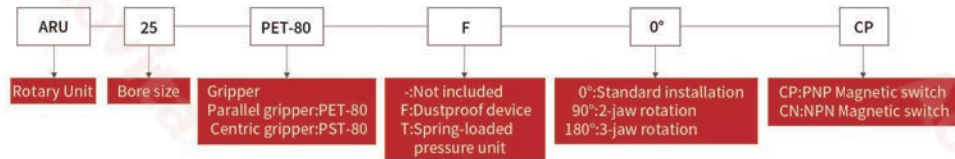

Each rotary unit requires two sensors. Each gripper requires a minimum of two sensors(one for open position, one for closed position).

Model	ARU-25	Model	PET-80	Model	PST-80
Theoretical torque	5Nm	Gripping force(closed)	400N	Gripping force(closed)	1000N
Swivel angle	180°	Gripping force(open)	450N	Gripping force(open)	1080N
Bore size	φ25mm	Workpiece weight	2kg	Workpiece weight	3kg
Shock absorber	Hydraulic shock absorber	Repeatability	0.02mm	Repeatability	0.05mm
Repeatability	0.02mm	Stroke per jaw	8mm	Stroke per jaw	8mm
Operating pressure	0.3-0.8MPa	Max. finger length	110mm	Max. finger length	110mm
Nominal pressure	0.6MPa	Max. weight per finger	0.6kg	Max. weight per finger	0.6kg
IP class	IP40	Operating pressure	0.3-0.8MPa	Operating pressure	0.3-0.8MPa
Air consumption	180ml per cycle	Nominal pressure	0.6MPa	Nominal pressure	0.6MPa
Weight	3kg	IP class	IP40	IP class	IP40
Operating temperature	0-80°C	Operating temperature	0-80°C	Operating temperature	0-80°C

Dimensions

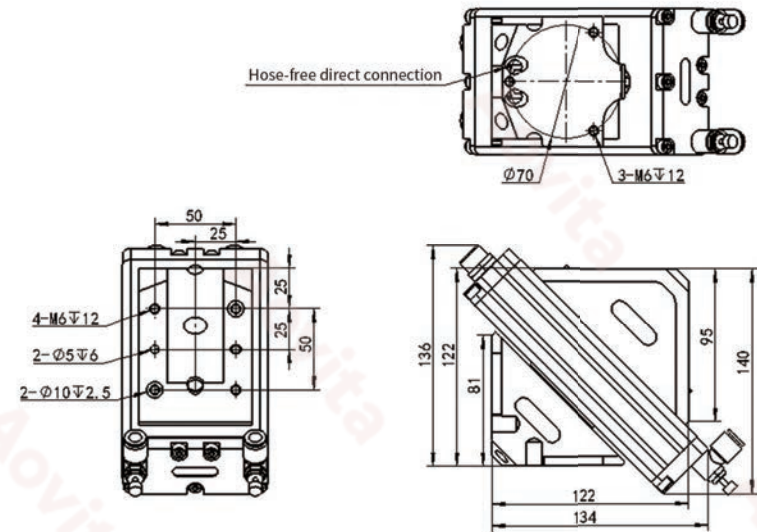

Mounting Options

Centric gripper - 0°

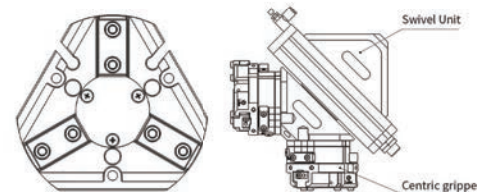

Centric gripper - 180° rotated

Adapter plates available in various thicknesses to suit different requirements.

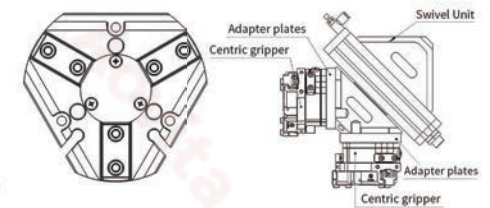

Parallel gripper - 0°

Adapter plates available in various thicknesses to suit different requirements.

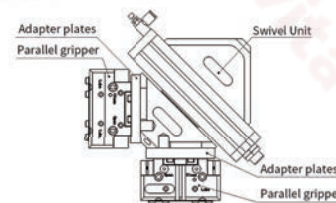

Parallel gripper - 90° rotated

Adapter plates available in various thicknesses to suit different requirements.

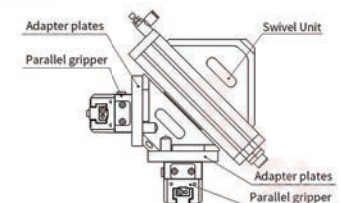



□ ARU-30



■ Selection

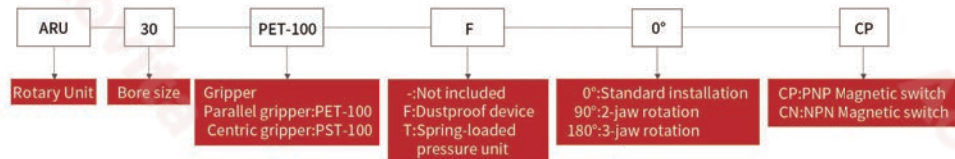

Each rotary unit requires two sensors. Each gripper requires a minimum of two sensors (one for open position, one for closed position).

Model	ARU-30	Model	PET-100	Model	PST-100
Theoretical torque	10Nm	Gripping force(closed)	700N	Gripping force(closed)	1800N
Swivel angle	180°	Gripping force(open)	750N	Gripping force(open)	1900N
Bore size	φ30mm	Workpiece weight	3kg	Workpiece weight	5kg
Shock absorber	Hydraulic shock absorber	Repeatability	0.02mm	Repeatability	0.02mm
Repeatability	0.02mm	Stroke per jaw	10mm	Stroke per jaw	10mm
Operating pressure	0.3-0.8MPa	Max. finger length	125mm	Max. finger length	125mm
Nominal pressure	0.6MPa	Max. weight per finger	1.1kg	Max. weight per finger	1.1kg
IP class	IP40	Operating pressure	0.3-0.8MPa	Operating pressure	0.3-0.8MPa
Air consumption	360ml per cycle	Nominal pressure	0.6MPa	Nominal pressure	0.6MPa
Weight	5kg	IP class	IP40	IP class	IP40
Operating temperature	0-80°C	Operating temperature	0-80°C	Operating temperature	0-80°C

■ Dimensions

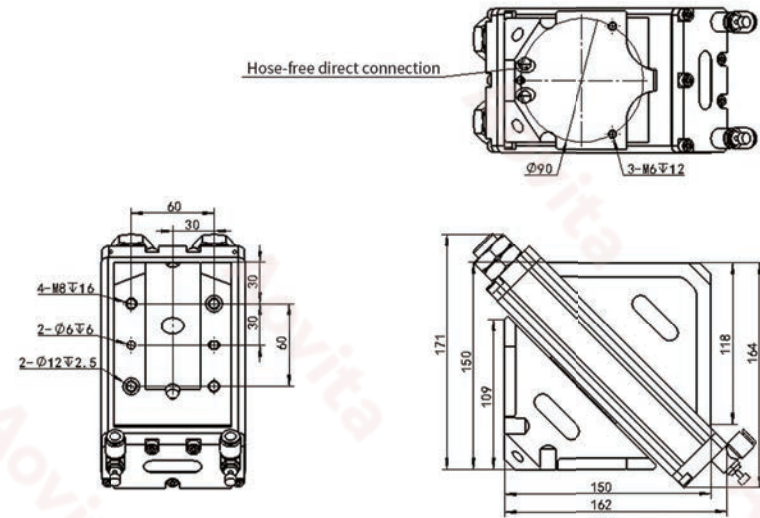

■ Mounting Options

• Centric gripper - 0°

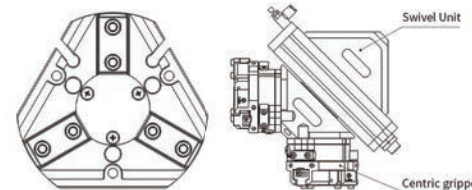

• Centric gripper - 180° rotated

Adapter plates available in various thicknesses to suit different requirements.

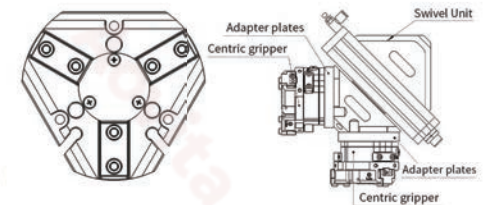

• Parallel gripper - 0°

Adapter plates available in various thicknesses to suit different requirements.

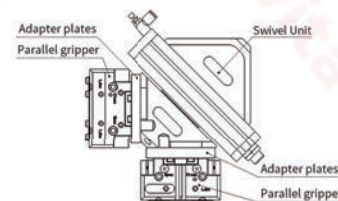

• Parallel gripper - 90° rotated

Adapter plates available in various thicknesses to suit different requirements.

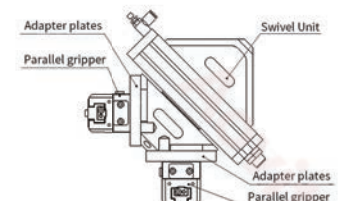

ARU-40



Selection

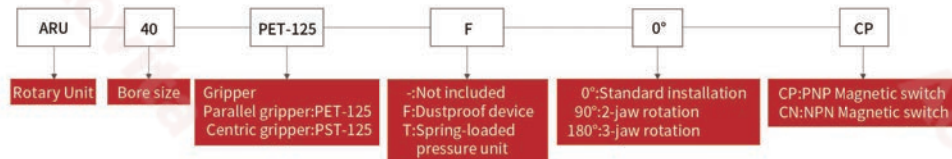

Each rotary unit requires two sensors. Each gripper requires a minimum of two sensors(one for open position, one for closed position).

Model	ARU-40	Model	PET-125	Model	PST-125
Theoretical torque	40Nm	Gripping force(closed)	1000N	Gripping force(closed)	3100N
Swivel angle	180°	Gripping force(open)	1100N	Gripping force(open)	3200N
Bore size	φ40mm	Workpiece weight	5.5kg	Workpiece weight	10kg
Shock absorber	Hydraulic shock absorber	Repeatability	0.02mm	Repeatability	0.02mm
Repeatability	0.02mm	Stroke per jaw	13mm	Stroke per jaw	13mm
Operating pressure	0.3-0.8MPa	Max. finger length	170mm	Max. finger length	170mm
Nominal pressure	0.6MPa	Max. weight per finger	2kg	Max. weight per finger	2kg
IP class	IP40	Operating pressure	0.3-0.8MPa	Operating pressure	0.3-0.8MPa
Air consumption	690ml per cycle	Nominal pressure	0.6MPa	Nominal pressure	0.6MPa
Weight	10kg	IP class	IP40	IP class	IP40
Operating temperature	0-80°C	Operating temperature	0-80°C	Operating temperature	0-80°C

Dimensions

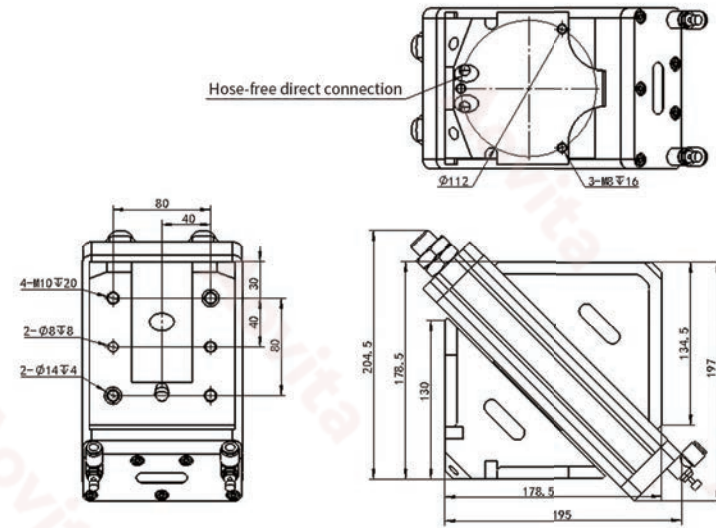

Mounting Options

Centric gripper - 0°

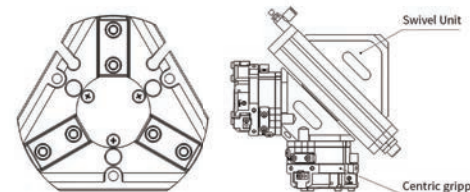

Centric gripper - 180° rotated

Adapter plates available in various thicknesses to suit different requirements.

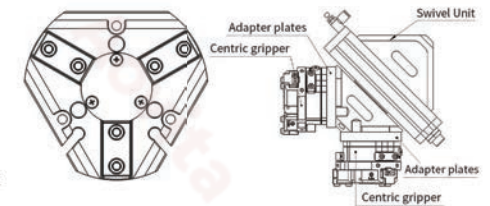

Parallel gripper - 0°

Adapter plates available in various thicknesses to suit different requirements.

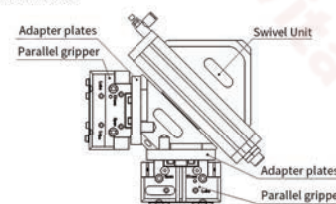

Parallel gripper - 90° rotated

Adapter plates available in various thicknesses to suit different requirements.

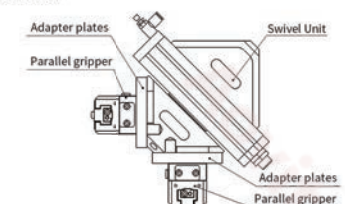



## Aovita ATU Rotary Wrist

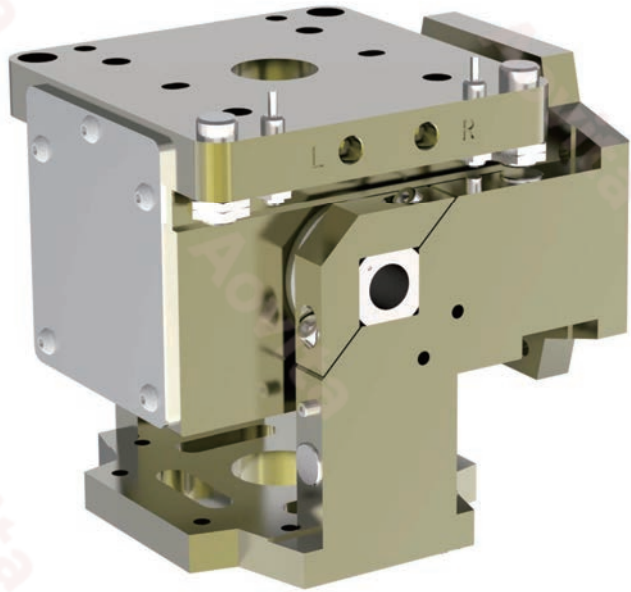

- Heavy Payload
- Precise
- Adjustable
- Reliable

### ■ Application

90° reversing robot solution for standard machine tool loading/unloading.

### ■ Advantages

- ① Dual-piston drive for maximum gripping force.
- ② Precision rack-and-pinion drive for outstanding repeatability.
- ③ Built-in positioning screws allow for fine-tuning of the angle.
- ④ Standardized design allows integration with various robots without adapter plate.

## Optional Modules

Tailored to industry-specific requirements

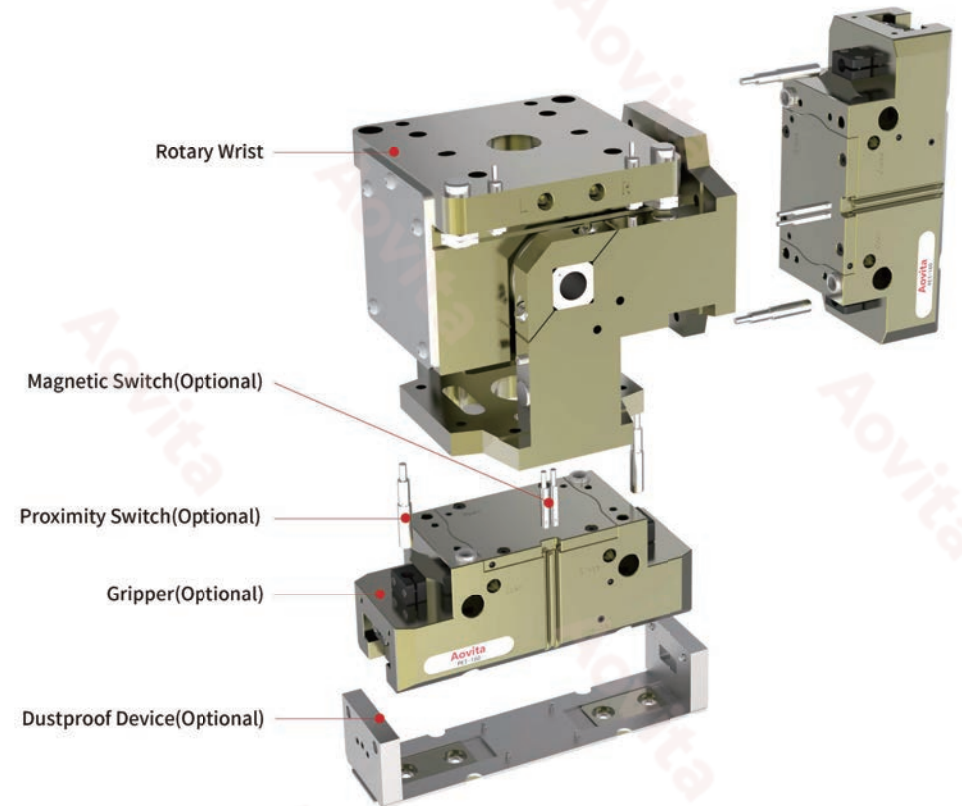

Model	Bore size [mm]	Theoretical torque [Nm]	Recommended workpiece weight per jaw [kg]
ATU-40	40	12	2
ATU-50	50	19	3
ATU-63	63	36	5.5
ATU-80	80	86	8
ATU-100	100	150	13

□ ATU-40

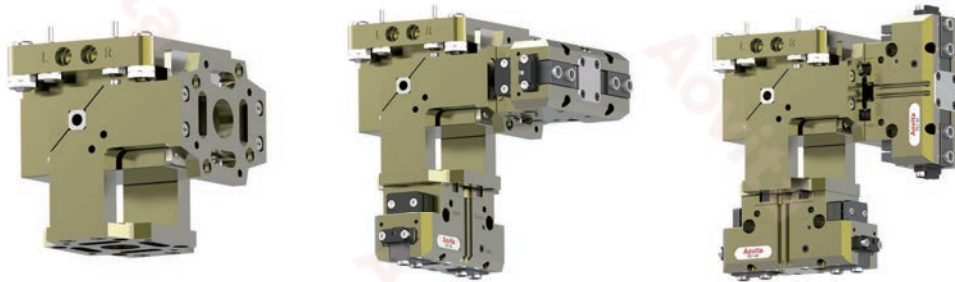

■ Selection

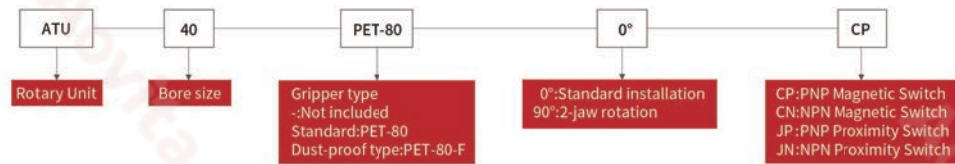

Each gripper requires a minimum of two sensors(one for open position, one for closed position).

Model	ATU-40
Theoretical torque	12Nm
Swivel angle	90°
Adjustability of end	3°
Bore size	φ40mm
Repeatability	0.05mm
Operating pressure	0.3-0.8MPa
Nominal pressure	0.6MPa
No-load rotation time	0.5s
IP class	IP30
Air consumption per cycle	29ml
Weight	1.4kg
Operating temperature	5-50°C

Model	PET-80
Gripping force(closed)	400N
Gripping force(open)	450N
Workpiece weight	2kg
Repeatability	0.02mm
Stroke per jaw	8mm
Max. finger length	110mm
Max. weight per finger	0.6kg
Closing/opening time	0.04s
Operating pressure	0.3-0.8MPa
Nominal pressure	0.6MPa
IP class	IP40
Operating temperature	0-80°C

■ Dimensions

No.	Function
L	Counter-clockwise rotation
R	Clockwise rotation
①	Rotary unit mounting holes
②	Positioning pin holes
③	Robot mounting
④	Positioning pins(Included)
⑤	Magnetic switch
⑥	Proximity switch
⑦	Extended mounting holes

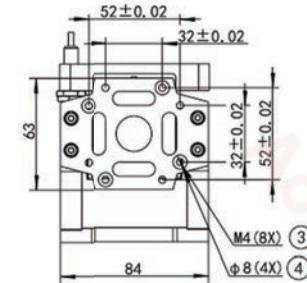
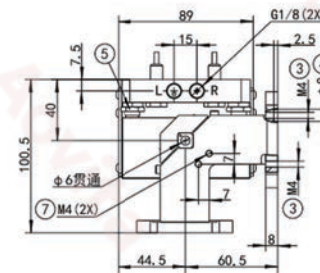
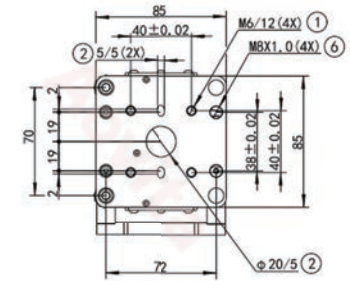

■ Mounting Options

● Parallel gripper - 0°

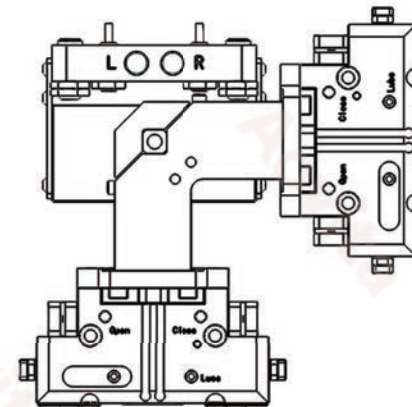

● Parallel gripper - 90° rotated

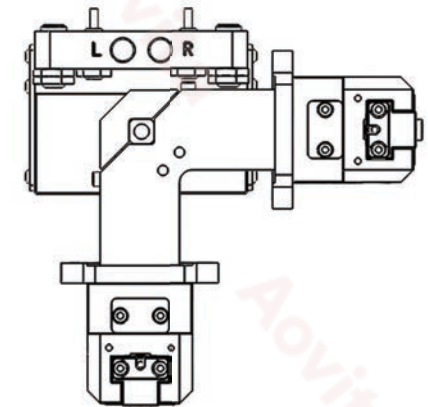



□ ATU-50

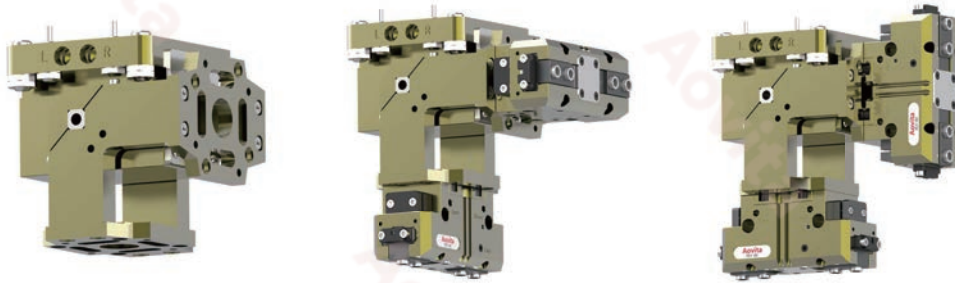

■ Selection

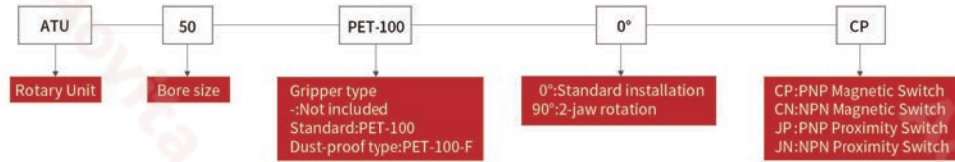

Each gripper requires a minimum of two sensors( one for open position, one for closed position).

Model	ATU-50
Theoretical torque	19Nm
Swivel angle	90°
Adjustability of end	3°
Bore size	φ50mm
Repeatability	0.05mm
Operating pressure	0.3-0.8MPa
Nominal pressure	0.6MPa
No-load rotation time	0.5s
IP class	IP30
Air consumption per cycle	55ml
Weight	2.3kg
Operating temperature	5-50°C

Model	PET-100
Gripping force(closed)	700N
Gripping force(open)	750N
Workpiece weight	3kg
Repeatability	0.02mm
Stroke per jaw	10mm
Max. finger length	125mm
Max. weight per finger	1.1kg
Closing/opening time	0.08s
Operating pressure	0.3-0.8MPa
Nominal pressure	0.6MPa
IP class	IP40
Operating temperature	0-80°C

■ Dimensions

No.	Function
L	Counter-clockwise rotation
R	Clockwise rotation
①	Rotary unit mounting holes
②	Positioning pin holes
③	Robot mounting
④	Positioning pins(Included)
⑤	Magnetic switch
⑥	Proximity switch
⑦	Extended mounting holes

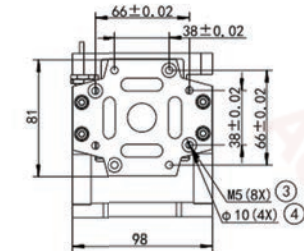
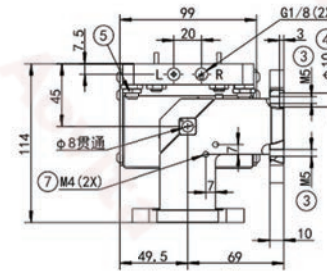
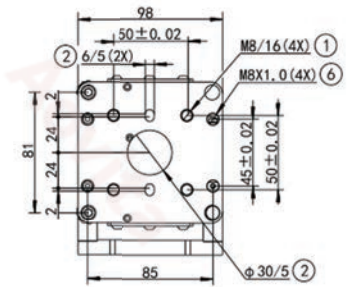

■ Mounting Options

● Parallel gripper - 0°

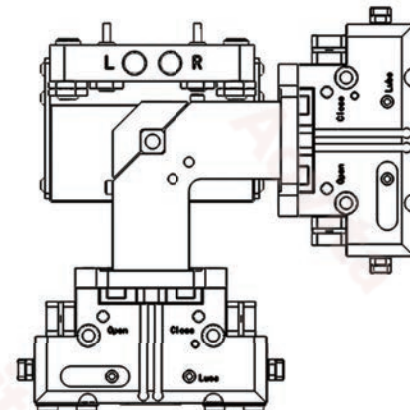

● Parallel gripper - 90° rotated

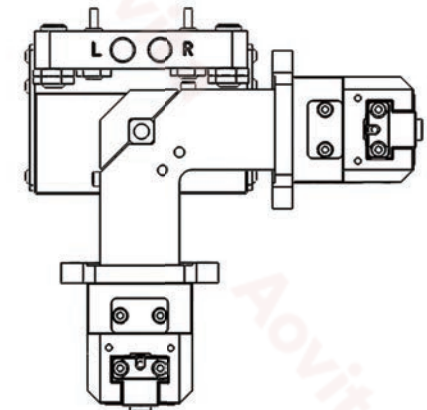

□ ATU-63

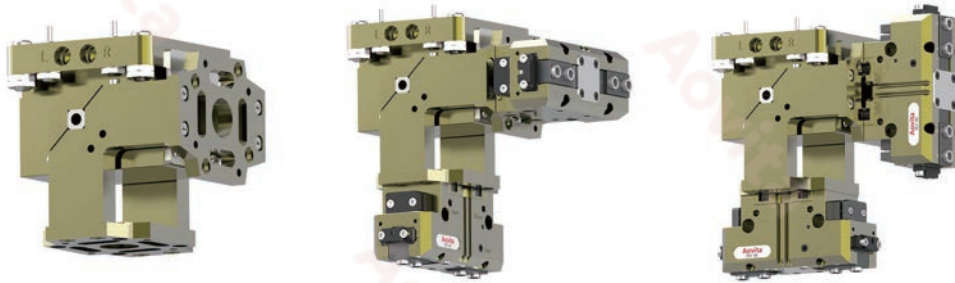

■ Selection

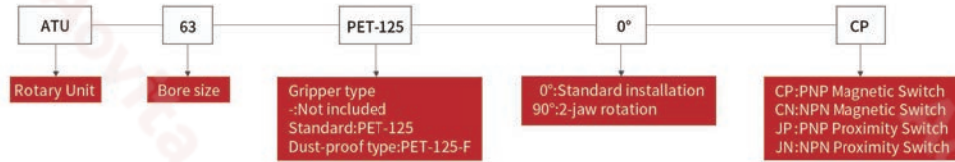

Each gripper requires a minimum of two sensors( one for open position, one for closed position).

Model	ATU-63
Theoretical torque	36Nm
Swivel angle	90°
Adjustability of end	3°
Bore size	φ63mm
Repeatability	0.05mm
Operating pressure	0.3-0.8MPa
Nominal pressure	0.6MPa
No-load rotation time	0.5s
IP class	IP30
Air consumption per cycle	110ml
Weight	4.1kg
Operating temperature	5-50°C

Model	PET-125
Gripping force(closed)	1000N
Gripping force(open)	1100N
Workpiece weight	5.5kg
Repeatability	0.02mm
Stroke per jaw	13mm
Max. finger length	170mm
Max. weight per finger	2kg
Closing/opening time	0.1s
Operating pressure	0.3-0.8MPa
Nominal pressure	0.6MPa
IP class	IP40
Operating temperature	0-80°C

■ Dimensions

No.	Function
L	Counter-clockwise rotation
R	Clockwise rotation
①	Rotary unit mounting holes
②	Positioning pin holes
③	Robot mounting
④	Positioning pins(Included)
⑤	Magnetic switch
⑥	Proximity switch
⑦	Extended mounting holes

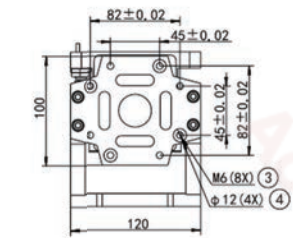
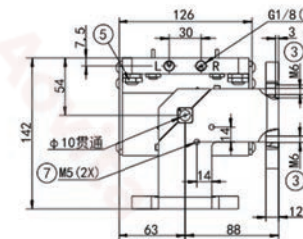
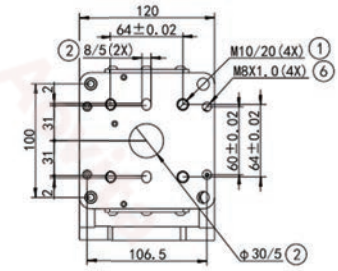

■ Mounting Options

● Parallel gripper - 0°

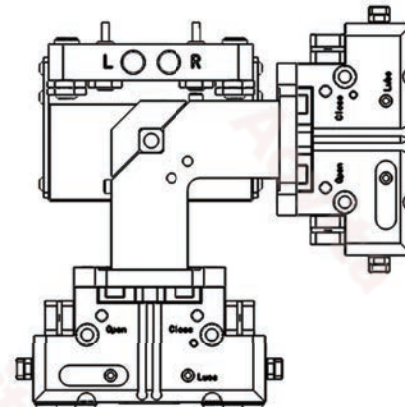

● Parallel gripper - 90° rotated

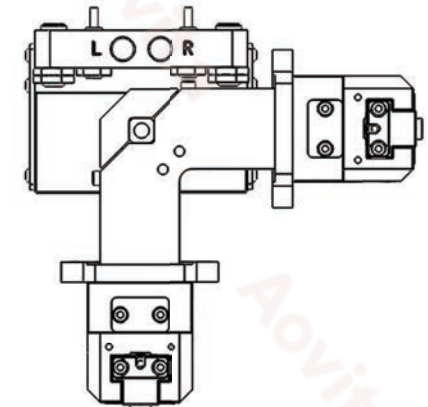



□ ATU-80

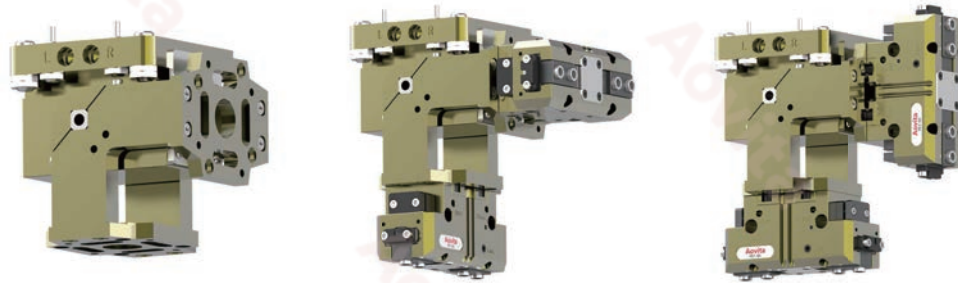

■ Selection

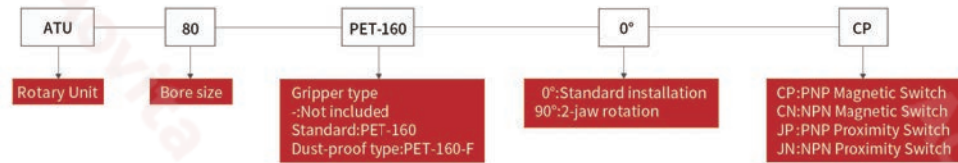

Each gripper requires a minimum of two sensors(one for open position, one for closed position).

Model	ATU-80
Theoretical torque	86Nm
Swivel angle	90°
Adjustability of end	3°
Bore size	φ40mm
Repeatability	0.05mm
Operating pressure	0.3-0.8MPa
Nominal pressure	0.6MPa
No-load rotation time	0.5s
IP class	IP30
Air consumption per cycle	200ml
Weight	6.3kg
Operating temperature	5-50°C

Model	PET-160
Gripping force(closed)	1600N
Gripping force(open)	1700N
Workpiece weight	8kg
Repeatability	0.02mm
Stroke per jaw	16mm
Max. finger length	200mm
Max. weight per finger	3kg
Closing/opening time	0.15s
Operating pressure	0.3-0.8MPa
Nominal pressure	0.6MPa
IP class	IP40
Operating temperature	0-80°C

■ Dimensions

No.	Function
L	Counter-clockwise rotation
R	Clockwise rotation
①	Rotary unit mounting holes
②	Positioning pin holes
③	Robot mounting
④	Positioning pins(Included)
⑤	Magnetic switch
⑥	Proximity switch
⑦	Extended mounting holes

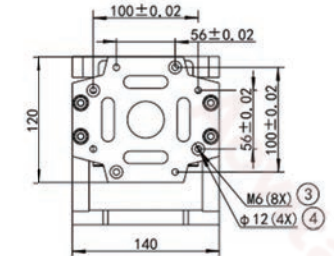
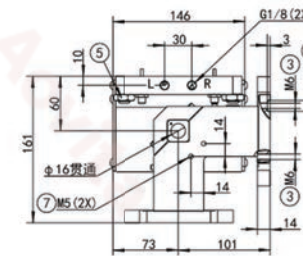
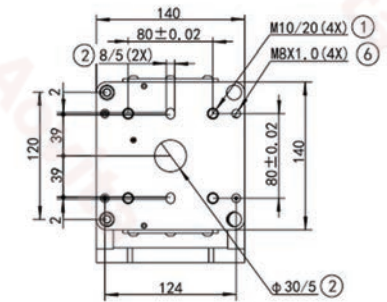

■ Mounting Options

● Parallel gripper - 0°

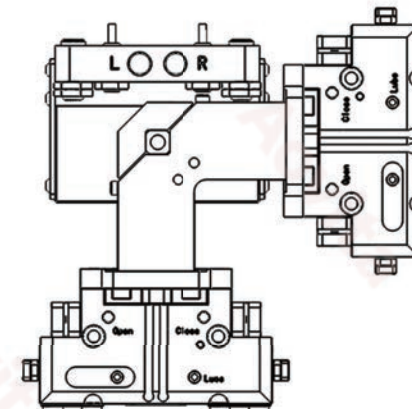

● Parallel gripper - 90° rotated

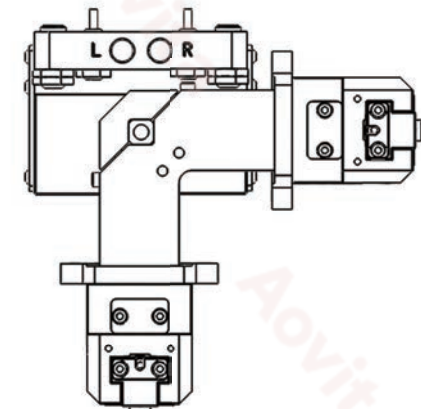

□ ATU-100

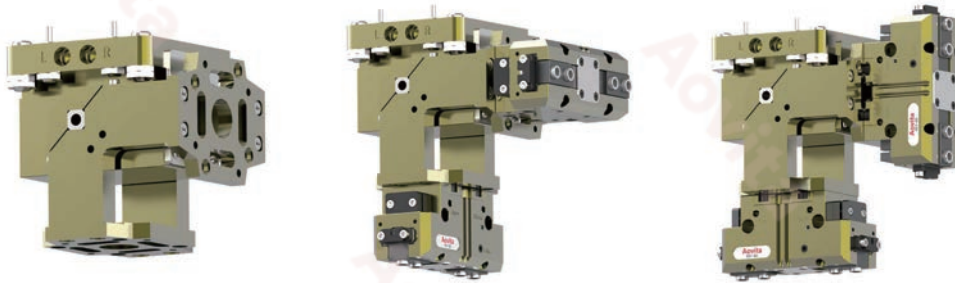

■ Selection

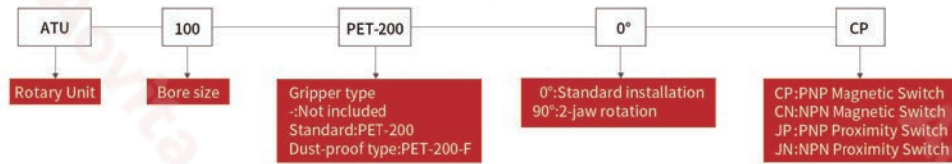

Each gripper requires a minimum of two sensors( one for open position, one for closed position).

Model	ATU-100
Theoretical torque	150Nm
Swivel angle	90°
Adjustability of end	3°
Bore size	φ100mm
Repeatability	0.05mm
Operating pressure	0.3-0.8MPa
Nominal pressure	0.6MPa
No-load rotation time	0.5s
IP class	IP30
Air consumption per cycle	510ml
Weight	11.8kg
Operating temperature	5-50°C

Model	PET-200
Gripping force(closed)	2700N
Gripping force(open)	2800N
Workpiece weight	13kg
Repeatability	0.05mm
Stroke per jaw	25mm
Max. finger length	240mm
Max. weight per finger	6kg
Closing/opening time	0.35s
Operating pressure	0.3-0.8MPa
Nominal pressure	0.6MPa
IP class	IP40
Operating temperature	0-80°C

■ Dimensions

No.	Function
L	Counter-clockwise rotation
R	Clockwise rotation
①	Rotary unit mounting holes
②	Positioning pin holes
③	Robot mounting
④	Positioning pins(Included)
⑤	Magnetic switch
⑥	Proximity switch
⑦	Extended mounting holes

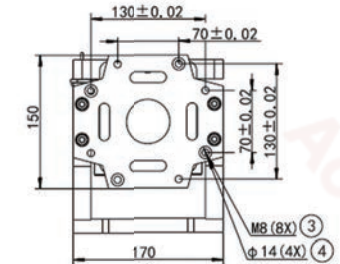
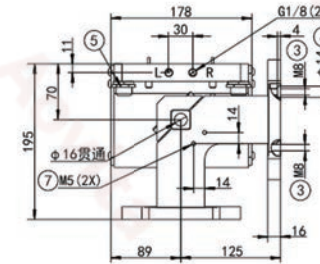
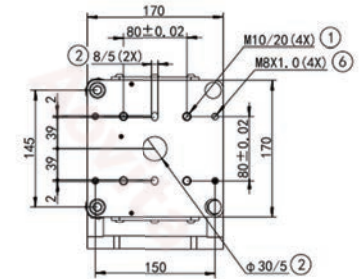

■ Mounting Options

● Parallel gripper - 0°

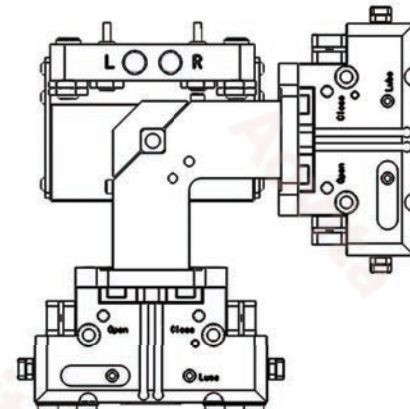

● Parallel gripper - 90° rotated

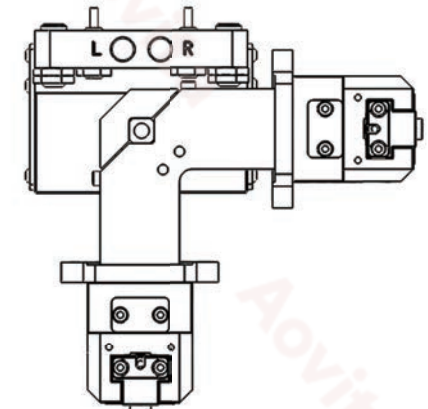



## Aovita ACU6 Flexible Compensation Unit



- Flexible
- Compact
- Robust

### ■ Application

Universal solution for multiple industries. Ideal for mechanical engineering, assembly & material handling, and automotive production – in clean to lightly dusty environments.

### ■ Advantages

- ① Direct robot flange connection – no adapter plate required.
- ② Optimal deflection with springs for self-reset or pneumatic reset.
- ③ Central locking ensures fixed centering position.
- ④ Flexible compensation through rotation and angular deflection.

Model	Dimensions for direct connection to robot end flange [mm]	Weight [kg]
ACU6-50	50	0.6
ACU6-63	63	0.9
ACU6-80	80	1.6
ACU6-100	100	2.5

## Aovita ACU3 Planar Compensation Unit



- Smooth
- Lightweight
- Self-locking

### ■ Application

Enables centering, floating, and eccentric locking in the X-Y plane – delivering maximum torque load with minimal space.

### ■ Advantages

- ① Direct robot flange connection – no adapter plate required.
- ② Optimal deflection with springs for self-reset or pneumatic reset.
- ③ Central locking ensures fixed centering position.
- ④ Flexible compensation through rotation and angular deflection.

Model	Dimensions for direct connection to robot end flange [mm]	Weight [kg]
ACU3-50	50	0.46
ACU3-63	63	0.83
ACU3-80	80	1.49
ACU3-100	100	2.4

ACU6-50



Variable installation position

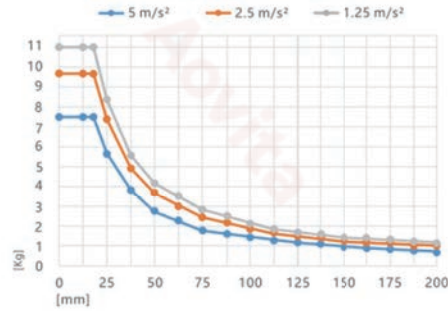

The diagram shows the direct relationship between maximum payload and acceleration and lever arm.

Specification

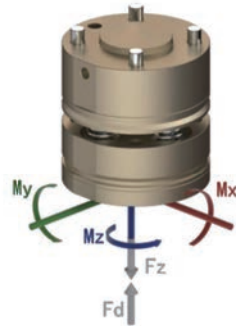

Model	ACU6-50
Compensation XY	±1mm
Compensation Z	5mm
Pitch angle	±2°
Adjustable mounting angle	±2.5°
Max. moment Mx	6.8Nm
Max. moment My	6.8Nm
Max. moment Mz	3.4Nm
Weight	0.6kg

Dimensions

No.	Function
A	Air connection locked
①	Robot-side connection
②	Tool-side connection
③	Threaded mounting holes
④	DIN EN ISO-9409-1: 2022 bolt circle
⑤	Positioning pin
⑥	Centering
⑦	Magnetic switch

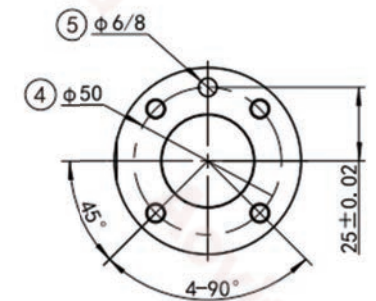
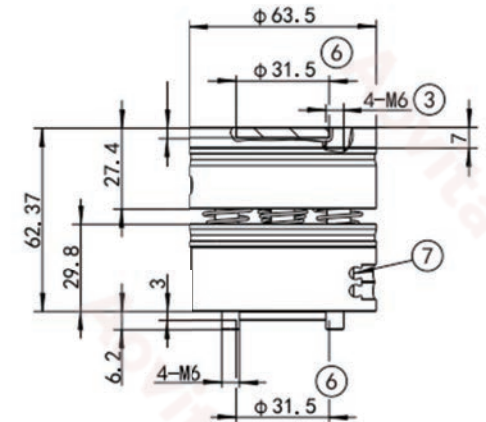
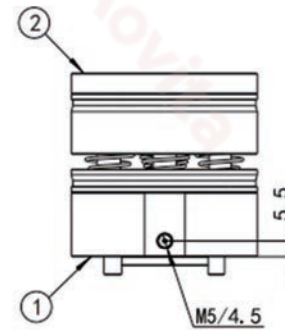
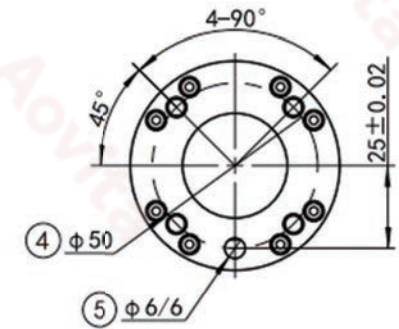



ACU6-63



Variable installation position

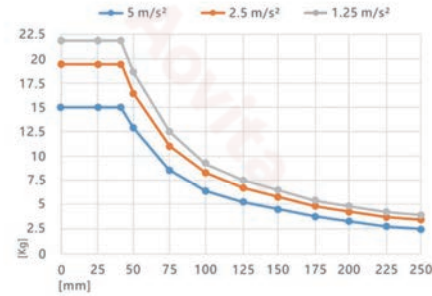

The diagram shows the direct relationship between maximum payload and acceleration and lever arm.

Specification



Model	ACU6-63
Compensation XY	±1mm
Compensation Z	9mm
Pitch angle	±3°
Adjustable mounting angle	±2.5°
Max. moment Mx	27.2Nm
Max. moment My	27.2Nm
Max. moment Mz	13.6Nm
Weight	0.9kg

Dimensions

No.	Function
A	Air connection locked
①	Robot-side connection
②	Tool-side connection
③	Threaded mounting holes
④	DIN EN ISO-9409-1: 2022 bolt circle
⑤	Positioning pin
⑥	Centering
⑦	Magnetic switch

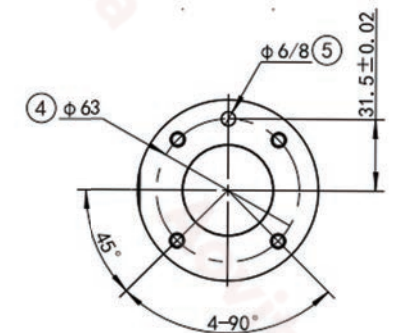
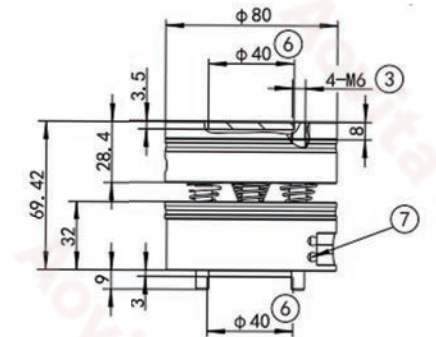
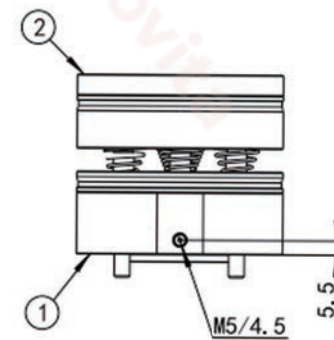
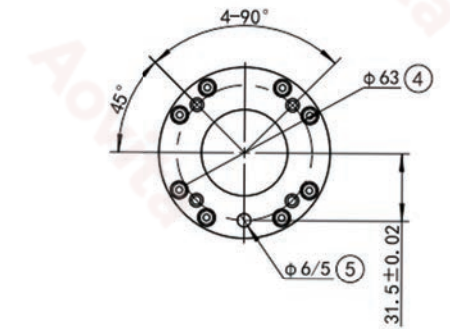

ACU6-80



Variable installation position

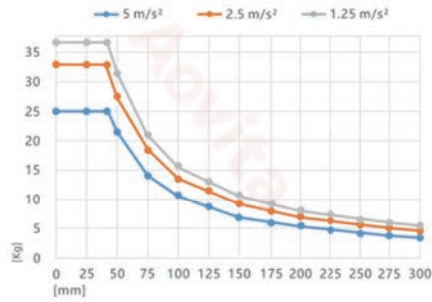

The diagram shows the direct relationship between maximum payload and acceleration and lever arm.

Specification



Model	ACU6-80
Compensation XY	±2mm
Compensation Z	10mm
Pitch angle	±3°
Adjustable mounting angle	±4.5°
Max. moment Mx	27.2Nm
Max. moment My	27.2Nm
Max. moment Mz	13.6Nm
Weight	1.6kg

Dimensions

No.	Function
A	Air connection locked
①	Robot-side connection
②	Tool-side connection
③	Threaded mounting holes
④	DINEN ISO-9409-1: 2022 bolt circle
⑤	Positioning pin
⑥	Centering
⑦	Magnetic switch

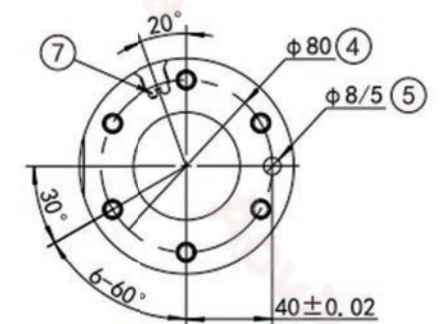
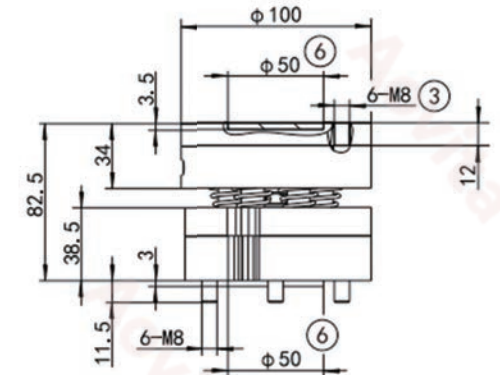
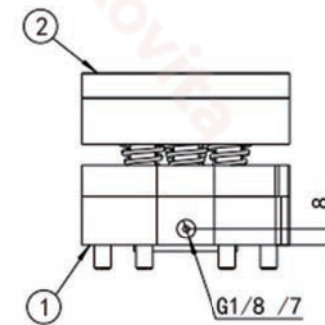
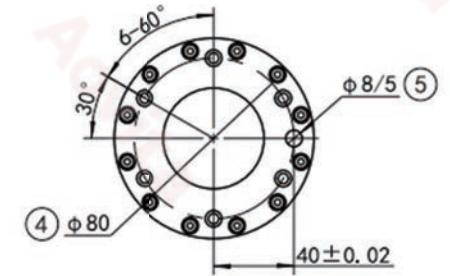



ACU6-100



Variable installation position

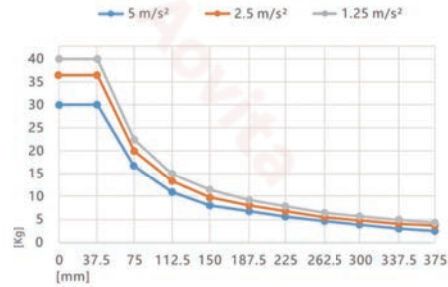

The diagram shows the direct relationship between maximum payload and acceleration and lever arm.

Specification



Model	ACU6-100
Compensation XY	±2.5mm
Compensation Z	10mm
Pitch angle	±4°
Adjustable mounting angle	±4°
Max. moment Mx	40.8Nm
Max. moment My	40.8Nm
Max. moment Mz	20.4Nm
Weight	2.5kg

Dimensions

No.	Function
A	Air connection locked
①	Robot-side connection
②	Tool-side connection
③	Threaded mounting holes
④	DINEN ISO-9409-1: 2022 bolt circle
⑤	Positioning pin
⑥	Centering
⑦	Magnetic switch

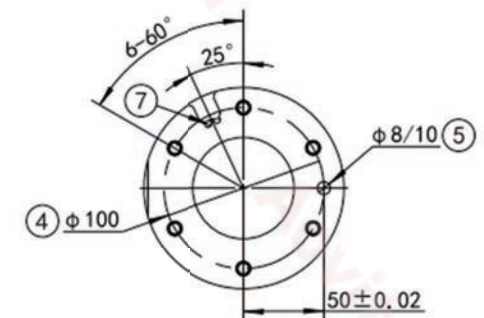
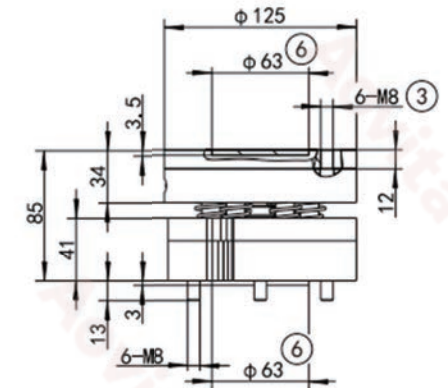
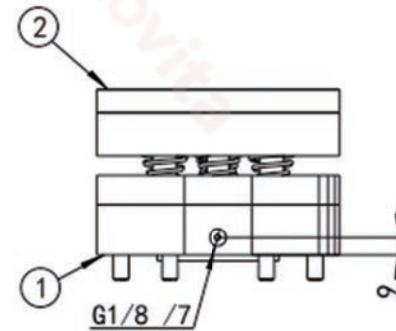
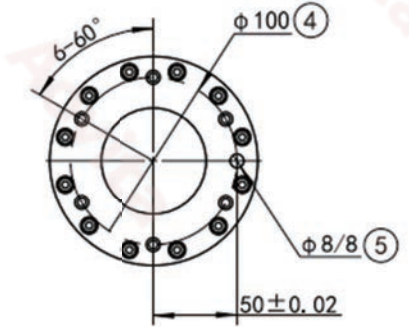

ACU3-50



Load chart

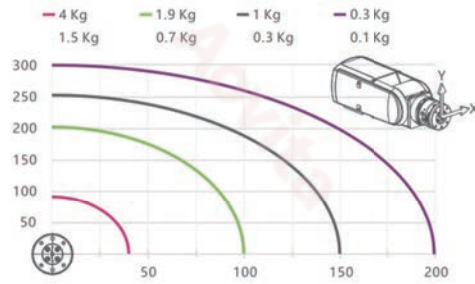

In horizontal applications, the permissible center of gravity position varies as a function of payload. Higher mass values apply for centering lock, while lower mass values apply for centering storage.

Specification

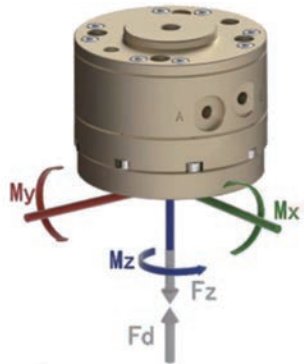

- Mx max. 16 Nm
- My max. 16 Nm
- Mz max. 3.5 Nm
- Fz max. 300 N
- Fd max. 1700 N

Model	ACU3-50
Compensation XY	±2.5mm
Deflection rotatory	±12°
Compensation weight, vertical	6kg
Compensation weight, horizontal	4kg
Locking force	235N
Max. locked holding force	130N
Max. distance shifting force Z	120mm
Operating pressure	0.3-0.8MPa
Repeatability	±0.02mm
Weight	0.46kg
Operating temperature	5-60°C

Dimensions

No.	Function
A	Air connection locked
B	Air connection unlocked
C	Air connection position memory
①	Robot-side connection
②	Tool-side connection
③	DIN EN ISO-9409-1:2022 bolt circle
④	Mounting bolt
⑤	Positioning pin
⑥	Centering
⑦	Magnetic switch

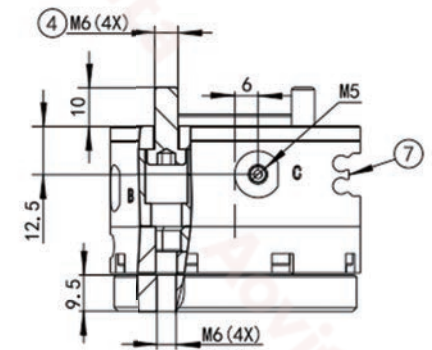
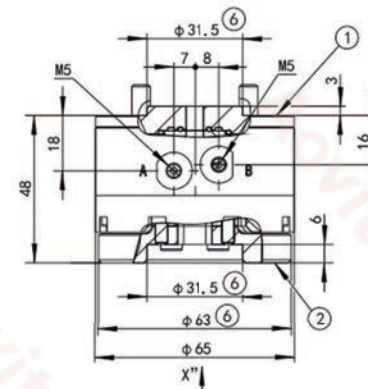
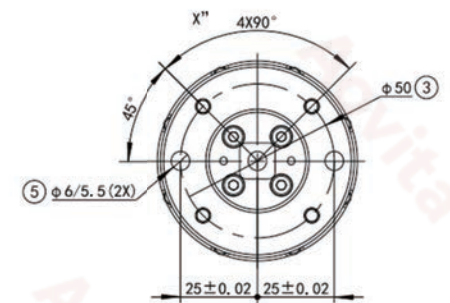
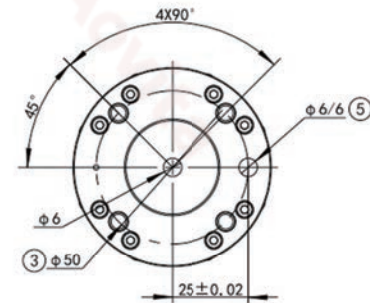



ACU3-63



Load chart

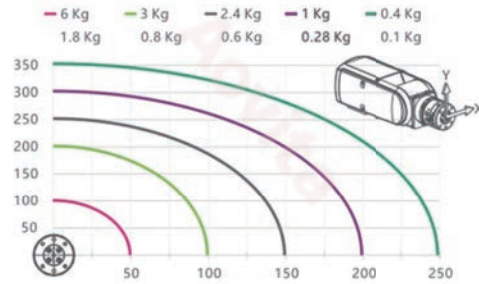

In horizontal applications, the permissible center of gravity position varies as a function of payload. Higher mass values apply for centering lock, while lower mass values apply for centering storage.

Specification

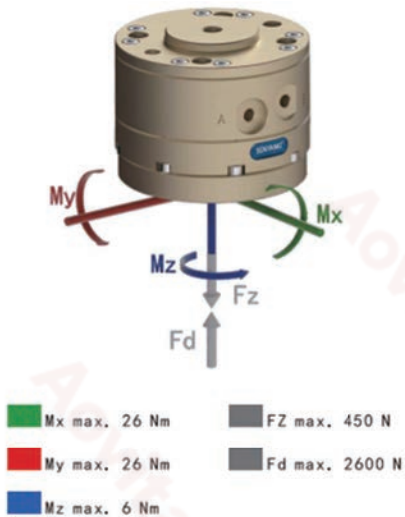

Model	ACU3-63
Compensation XY	$\pm 3$ mm
Deflection rotatory	$\pm 12^\circ$
Compensation weight, vertical	9kg
Compensation weight, horizontal	6kg
Locking force	370N
Max. locked holding force	200N
Max. distance shifting force Z	160mm
Operating pressure	0.3-0.8MPa
Repeatability	$\pm 0.02$ mm
Weight	0.83kg
Operating temperature	5-60°C

Dimensions

No.	Function
A	Air connection locked
B	Air connection unlocked
C	Air connection position memory
①	Robot-side connection
②	Tool-side connection
③	DIN EN ISO-9409-1: 2022 bolt circle
④	Mounting bolt
⑤	Positioning pin
⑥	Centering
⑦	Magnetic switch

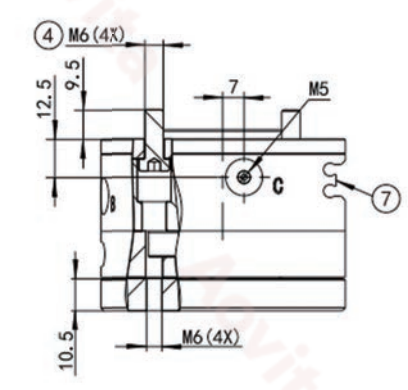
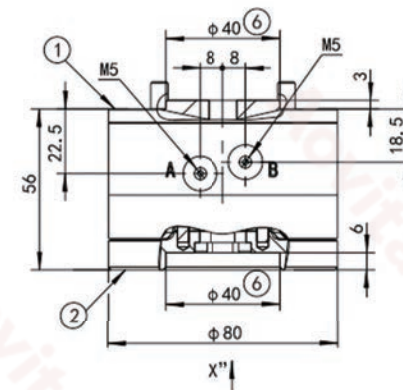
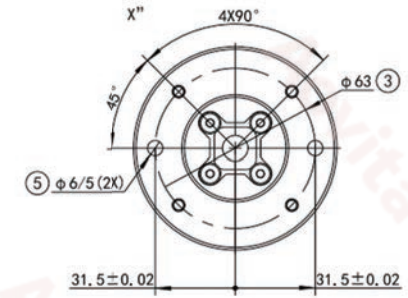
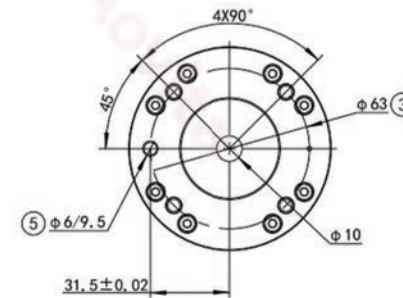

□ ACU3-80

■ Load chart

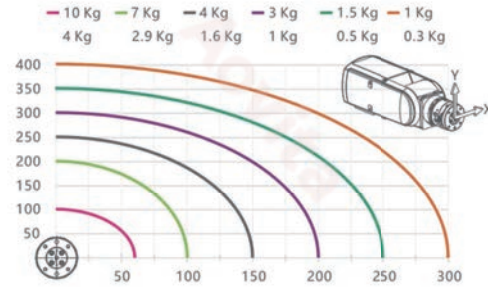

In horizontal applications, the permissible center of gravity position varies as a function of payload. Higher mass values apply for centering lock, while lower mass values apply for centering storage.

■ Dimensions

No.	Function
A	Air connection locked
B	Air connection unlocked
C	Air connection position memory
①	Robot-side connection
②	Tool-side connection
③	DIN EN ISO-9409-1: 2022 bolt circle
④	Mounting bolt
⑤	Positioning pin
⑥	Centering
⑦	Magnetic switch

■ Specification

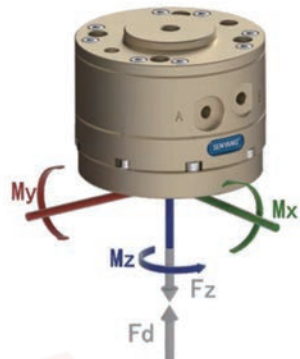

- Mx max. 30 Nm
- My max. 30 Nm
- Mz max. 9 Nm
- Fz max. 750 N
- Fd max. 3200 N

Model	ACU3-80
Compensation XY	±4mm
Deflection rotatory	±16°
Compensation weight, vertical	15kg
Compensation weight, horizontal	10kg
Locking force	580N
Max. locked holding force	310N
Max. distance shifting force Z	200mm
Operating pressure	0.3-0.8MPa
Repeatability	±0.02mm
Weight	1.49kg
Operating temperature	5-60°C

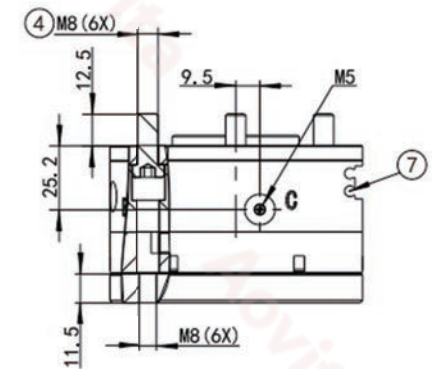
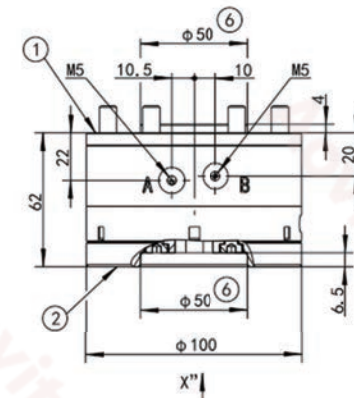
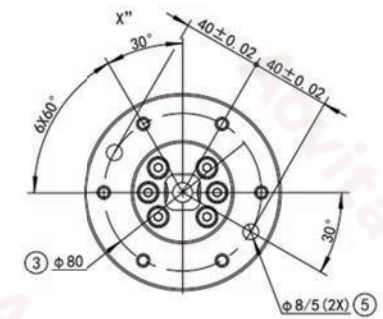
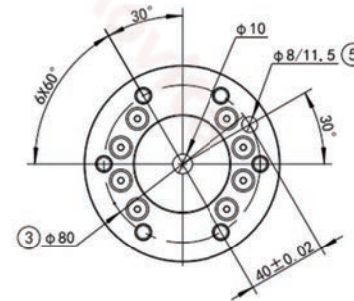



ACU3-100

Load chart

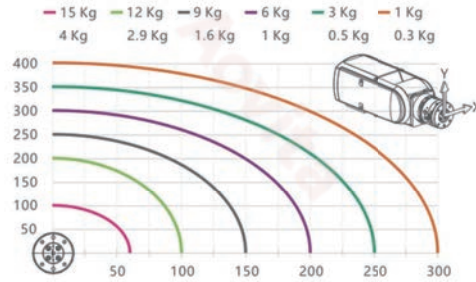

In horizontal applications, the permissible center of gravity position varies as a function of payload. Higher mass values apply for centering lock, while lower mass values apply for centering storage.

Specification

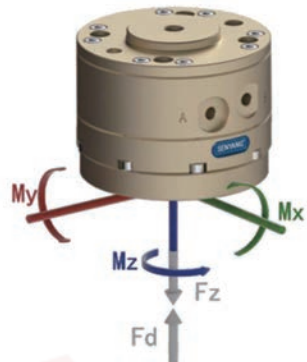

- Mx max. 45 Nm
- My max. 45 Nm
- Mz max. 15 Nm
- Fz max. 950 N
- Fd max. 4500 N

Model	ACU3-100
Compensation XY	±4mm
Deflection rotatory	±10°
Compensation weight, vertical	25kg
Compensation weight, horizontal	15kg
Locking force	960N
Max. locked holding force	800N
Max. distance shifting force Z	200mm
Operating pressure	0.3-0.8MPa
Repeatability	±0.02mm
Weight	2.4kg
Operating temperature	5-60°C

Dimensions

No.	Function
A	Air connection locked
B	Air connection unlocked
C	Air connection position memory
①	Robot-side connection
②	Tool-side connection
③	DIN EN ISO-9409-1: 2022 bolt circle
④	Mounting bolt
⑤	Positioning pin
⑥	Centering
⑦	Magnetic switch

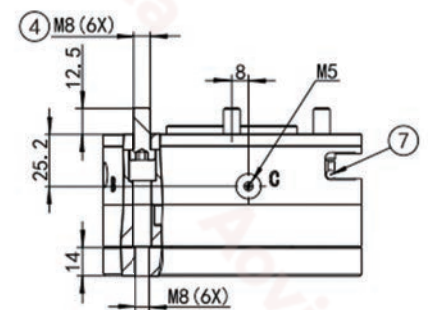
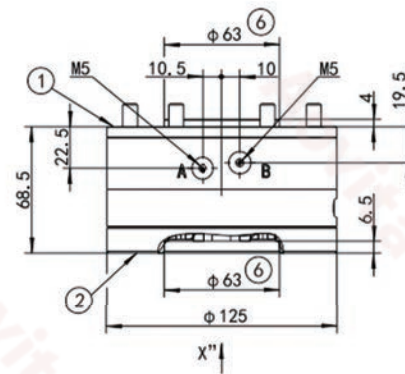
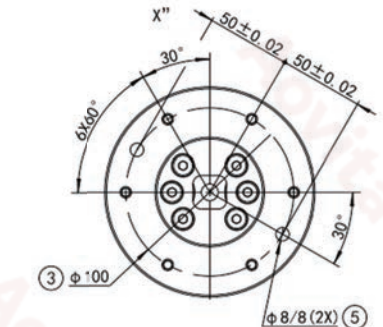
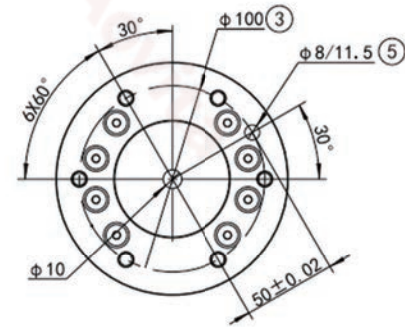

## Aovita AEM Magnetic Chuck

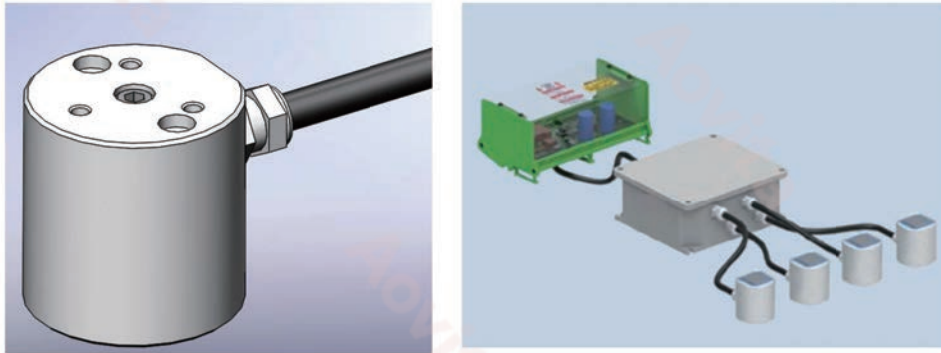

- Efficient
- Compact
- Low contamination
- Powerful performance
- Simple control

### ■ Application

Universal compact magnetic chuck for handling magnetic workpieces in clean to lightly contaminated environments.

### ■ Advantages

- ① Maximum magnetic force in minimal installation space for reliable part handling.
- ② Compact and lightweight design ensures portability for high-dynamic applications.
- ③ Holding force maintained even in emergency stop.

Model	Min. workpiece thickness	Effective payload on horizontal magnetic surface	Effective payload on vertical magnetic surface
AEM-30	6mm	18kg	7kg
AEM-50	12mm	82kg	32kg
AEM-70	16mm	165kg	65kg

## □ AEM-30

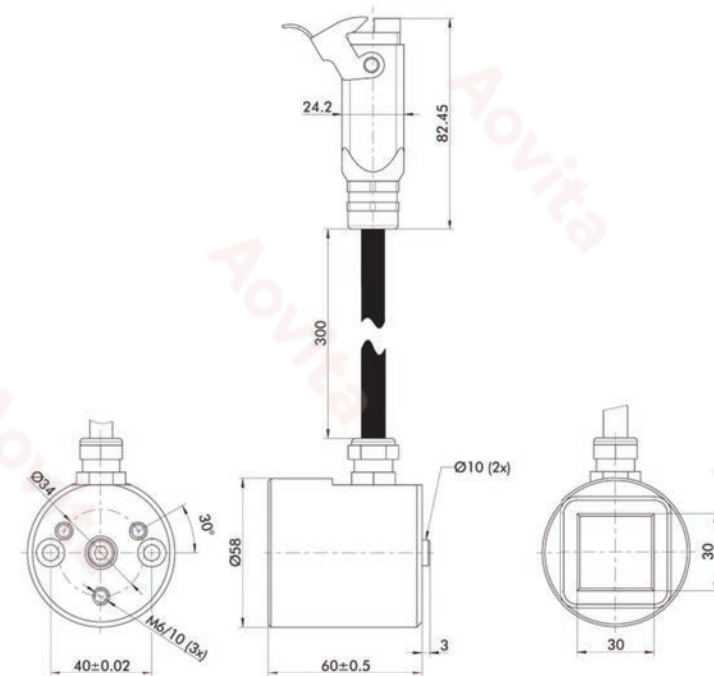

Model	AEM-30
Weight	1.3kg
Number of poles	2
Magnetic area	18.4cm <sup>2</sup>
Min. workpiece thickness	6mm
Effective payload on horizontal magnetic surface	18kg
Effective payload on vertical magnetic surface	7kg
Max. activations	20 times/minute
Module temperature rise at 15/25 times per minute	15/40°C
IP class	IP54
Current consumption during start/stop	3A
Cable length	30cm
Rated voltage	380V
Max. current	15A
Max. number of modules per controller	4



□ AEM-50

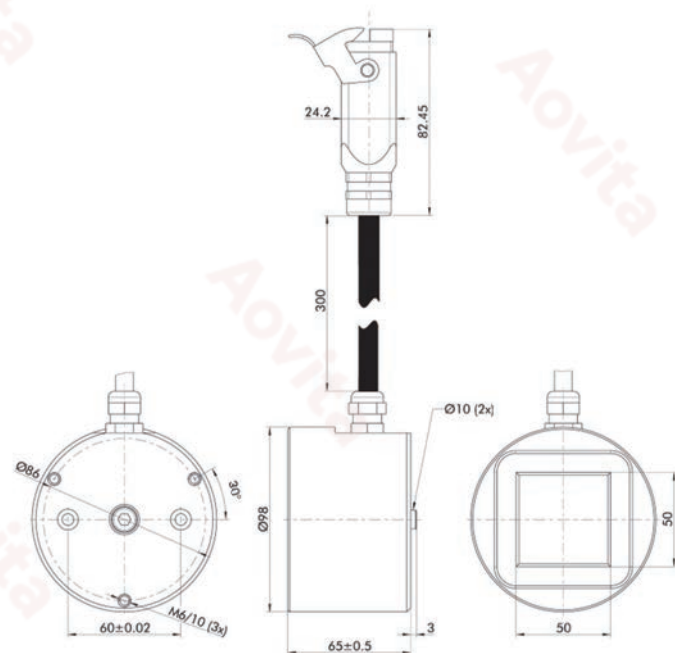

Model	AEM-50
Weight	3.5kg
Number of poles	2
Magnetic area	50.4cm <sup>2</sup>
Min. workpiece thickness	12mm
Effective payload on horizontal magnetic surface	80kg
Effective payload on vertical magnetic surface	32kg
Max. switching cycles per minute	6 times/minute
Module temperature rise under 15–25 starts per minute operation	40/80°C
IP class	IP54
Current consumption during start/stop	3A
Cable length	30cm
Rated voltage	380V
Max. current	15A
Max. number of modules per controller	4

□ AEM-70

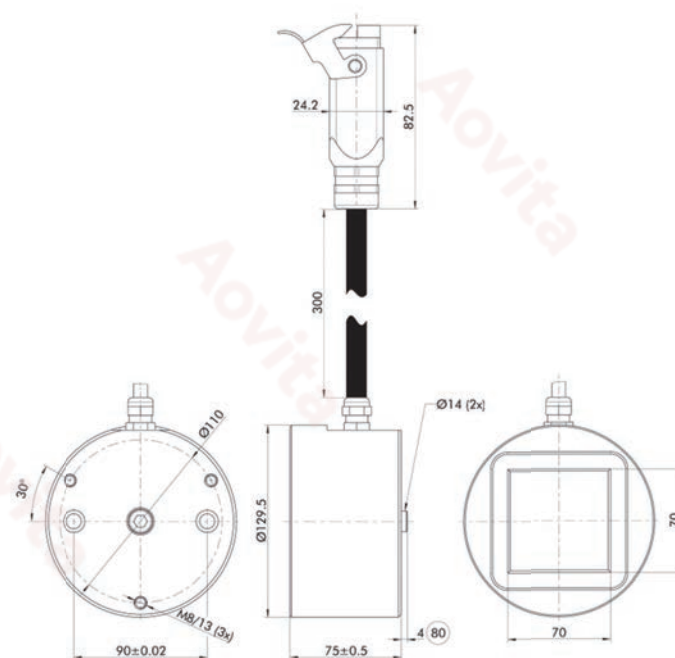

Model	AEM-70
Weight	7kg
Number of poles	2
Magnetic area	98.1cm <sup>2</sup>
Min. workpiece thickness	16mm
Effective payload on horizontal magnetic surface	165kg
Effective payload on vertical magnetic surface	65kg
Max. switching cycles per minute	10 times/minute
Module temperature rise under 15–25 starts per minute operation	25/60°C
IP class	IP54
Current consumption during start/stop	3.5A
Cable length	30cm
Rated voltage	380V
Max. current	15A
Max. number of modules per controller	4

# Aovita

## Product List



Robot tool changer standard

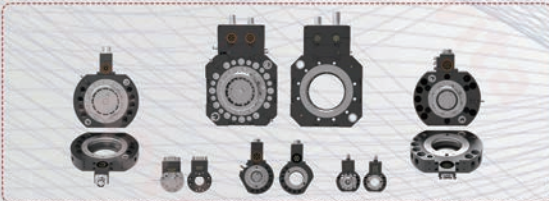

Aovita robot changer is used to change multiple sets of grippers by one robot. The robot can be used for multiple purposes.

### • Vacuum products •



**Vacuum suction cup**  
Used for gripping and handling of metal sheets, glass and plastic parts, etc



**Octopus sucker**  
Used for gripping and handling of products such as packing boxes, bags, etc



**Sponge sucker**  
Used for gripping and handling of products such as wooden boards, packing boxes, etc

### • Gripper •



**Pneumatic gripper**  
Used for gripping and handling of metal sheet workpieces



**Pneumatic gripper**  
Used in automatic loading and unloading systems for machining  
Used for gripping and handling of shafts/disks/shells and other workpieces

### • Magnetic suction •



**Magnetic chuck**  
Used for gripping and handling of metal sheet workpieces

### • Needle gripper •

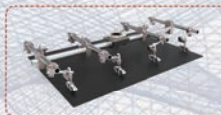

**Needle gripper**  
Used for gripping and handling of air permeable products such as carpets and felts, etc

### Intelligent gripper connector

Aovita connector can be used to quickly assemble various body frames for EOAT.



### • Vacuum product •

Aovita vacuum products can quickly combine the necessary grippers for metal stamping plate handling, logistics packaging handling, woodworking handling, injection molding handling, etc.



Pneumatic element of vacuum suction cup

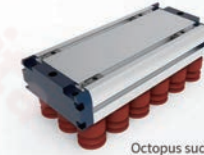

Octopus sucker



Sponge sucker

### • Clamp •

Aovita pneumatic gripper can be used to quickly assemble the grippers required for the handling of machining, loading & unloading, high-speed stamping and other work.



Gripper

Clamp

### • Magnetic suction •

Aovita magnetic chuck standard can be used to quickly assemble the grippers required for metal sheet handling and other work.



Magnetic chuck

### • Needle gripper •

Aovita needle suction cup can be used to quickly combine the grippers required for carpet and felt handling.



Needle suction cup